

OJ5154

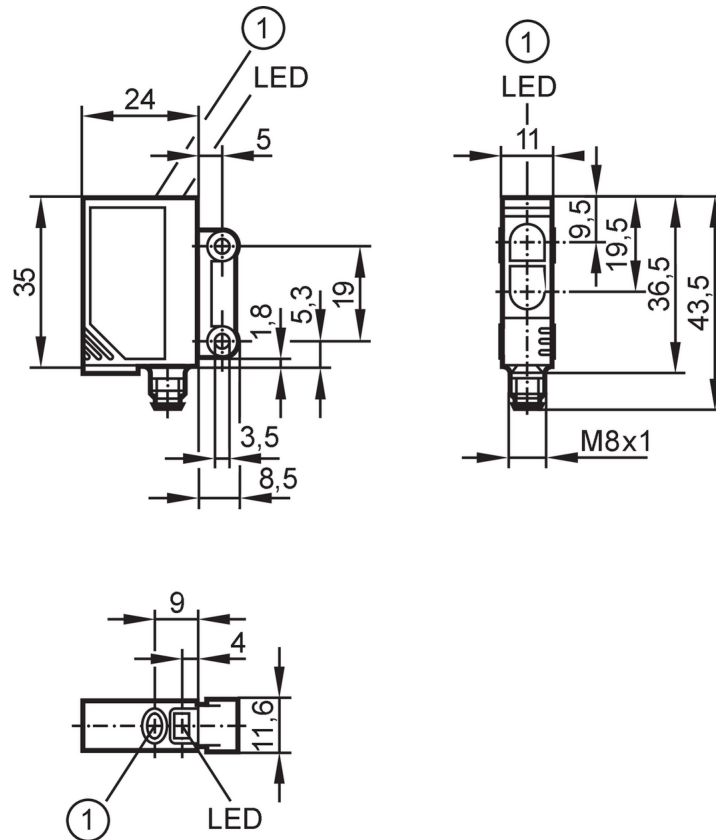

Laser diffuse reflection sensor

OJHLFPKG/SO/AS



- 1 pushbutton receiver in upper lens transmitter in lower lens



Product characteristics

Type of light	red light
Laser protection class	1
Housing	rectangular

Application

Special feature	Background suppression
Function principle	Diffuse reflection sensor
Application	For applications in robotics, assembly and handling technology

Electrical data

Operating voltage	[V]	10...30 DC
Current consumption	[mA]	13
Protection class		III
Reverse polarity protection		yes
Type of light		red light
Wave length	[nm]	650
Typ. lifetime	[h]	50000

Outputs

Electrical design	PNP
-------------------	-----

OJ5154



Laser diffuse reflection sensor

OJHLFPKG/SO/AS

Output function	light-on/dark-on mode; (programmable)	
Max. voltage drop switching output DC [V]		2.5
Permanent current rating of switching output DC [mA]		200
Switching frequency DC [Hz]		1000
Short-circuit protection		yes
Type of short-circuit protection		pulsed
Overload protection		yes

Detection zone		
Range [mm]	15...200; (white paper 200 x 200 mm 90% remission)	
Range adjustable		yes
Diameter of the smallest detectable object [mm]		2
Max. light spot width [mm]		2
Max. light spot height [mm]		1
Background suppression available		yes

Operating conditions		
Ambient temperature [°C]		-10...60
Protection		IP 67

Tests / approvals		
EMC	EN 60947-5-2	
Laser protection class		1
Notes on laser protection	Caution:	laser light
	laser class:	1
		EN / IEC60825-1:2007
		EN / IEC60825-1:2014
	Complies with 21 CFR 1040.10 except for conformance with IEC 60825-1 Ed. 3, as described in Laser Notice No. 56, dated May 8, 2019.	
MTTF [years]		501

Mechanical data		
Weight [g]		28.2
Housing		rectangular
Dimensions [mm]		35 x 11 x 24
Materials	housing: ABS; LED window: SEPS; pushbutton: SEPS	
Lens material		front pane:PMMA
Lens alignment		side lens

Displays / operating elements		
Display	switching status	1 x LED, yellow
	operation	1 x LED, green
Electronic lock		yes

OJ5154



Laser diffuse reflection sensor

OJHLFPKG/SO/AS

Accessories	
Items supplied	screws: 2
	spring washers: 2
	Nuts: 2

Remarks	
Remarks	operating voltage "supply class 2" according to cULus
Pack quantity	1 pcs.

Electrical connection

Connector: 1 x M8; coding: A; Contacts: 4

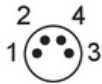

Connection

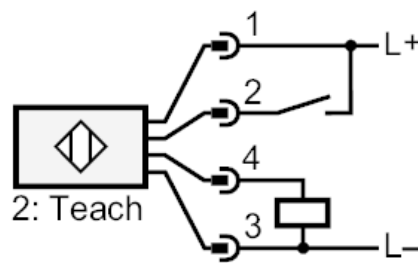

2 Teach

Diagrams and graphs

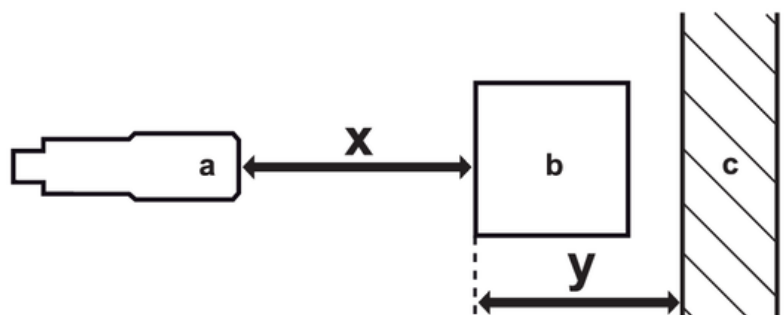

- a: sensor
- b: object
- c: background
- x: distance sensor/object [mm]
- y: min. distance object/background [mm]

OJ5154



Laser diffuse reflection sensor

OJHLFPKG/SO/AS

accuracy graph

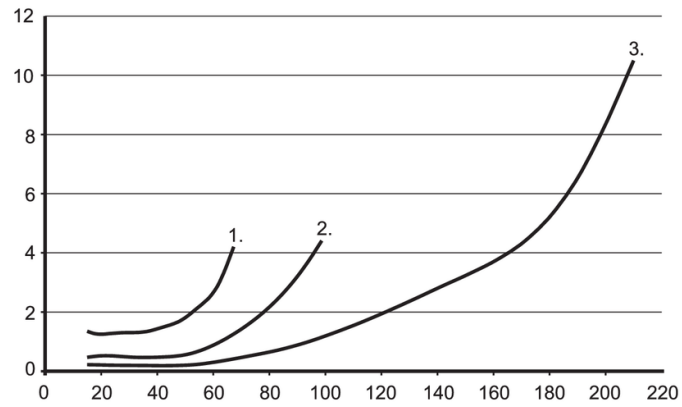

x: distance sensor/object [mm]

y: min. distance object/background [mm]

1 = object black (6 % remission) , background white (90 % remission)

2 = object grey (18 % remission) , background white (90 % remission)

3 = object white (90 % remission) , background white (90 % remission)