

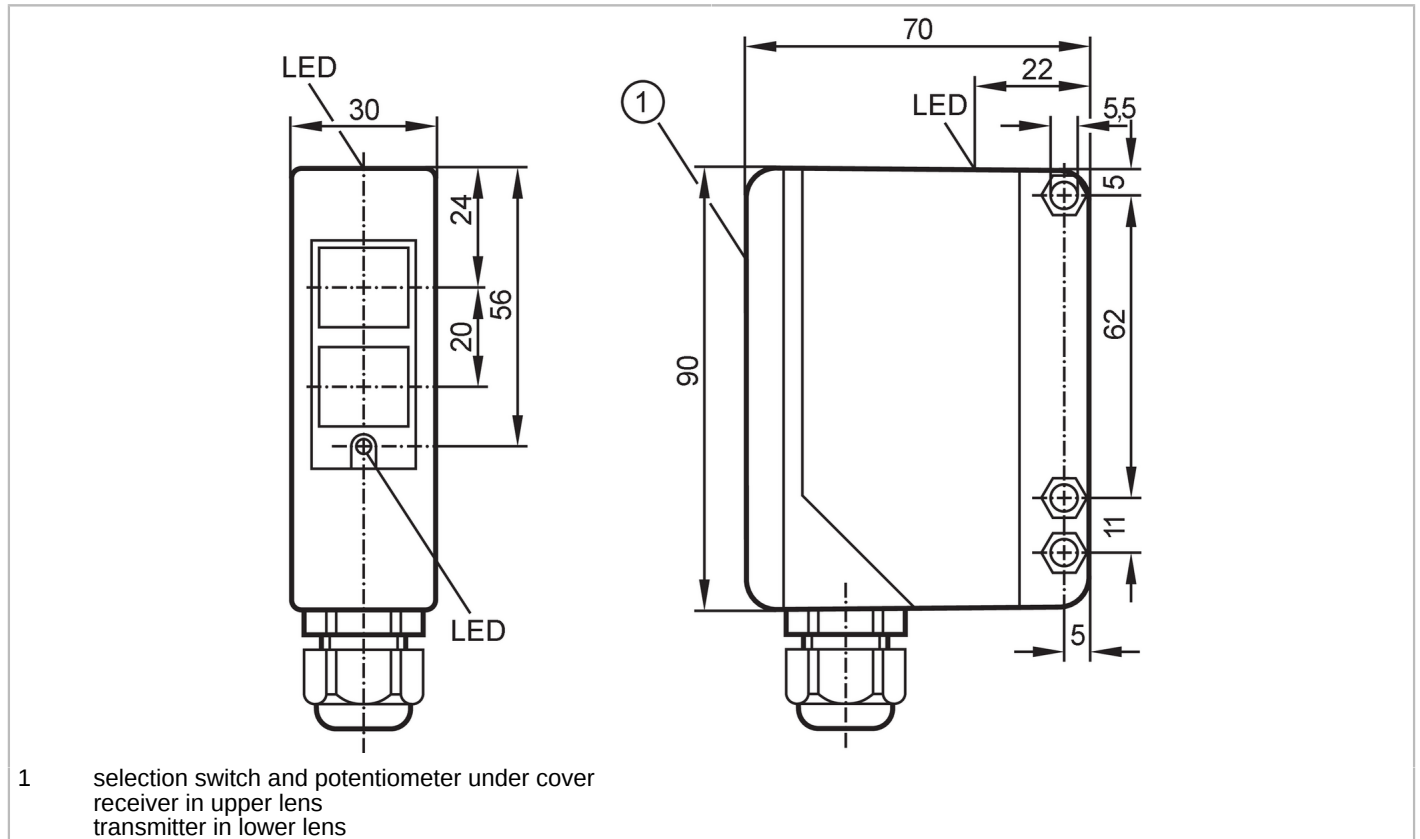

## Diffuse reflection sensor

OAT-FCKG/T



### Product characteristics

Type of light	infrared light
Housing	rectangular

### Application

Special feature	Function check output
Function principle	Diffuse reflection sensor
Application	Industrial applications / factory automation

### Electrical data

Operating voltage	[V]	10...36 DC
Current consumption	[mA]	< 50
Protection class		II
Reverse polarity protection		yes
Type of light		infrared light
Wave length	[nm]	875

### Outputs

Electrical design		PNP/NPN
Output function		light-on/dark-on mode; (programmable)
Function check output		yes
Max. current load for function check output	[mA]	10
Permanent current rating of switching output DC	[mA]	250

# OA5209



## Diffuse reflection sensor

OAT-FCKG/T

Max. current load in dual output mode	[mA]	100
Switching frequency DC	[Hz]	300
Short-circuit protection		yes
Type of short-circuit protection		pulsed
Overload protection		yes
Time function	[s]	0.5...10

### Detection zone

Range	[mm]	5...2750; (white paper 300 x 300 mm)
Range adjustable		yes

### Operating conditions

Ambient temperature	[°C]	-25...60
Protection		IP 65

### Tests / approvals

EMC	EN 60947-5-2	
	EN 55011	class B
MTTF	[years]	357

### Mechanical data

Weight	[g]	291
Housing		rectangular
Dimensions	[mm]	90 x 30 x 70
Materials		housing: PPO modified
Lens material		front pane:PMMA
Lens alignment		side lens

### Displays / operating elements

Display	switching status	1 x LED, yellow
	operation	1 x LED, green
	function	1 x LED, red
Operating elements		on-delay or off-delay selectable via slide switch

### Accessories

Items supplied		Angle bracket: 1, E20514 screwdrivers
----------------	--	--

### Remarks

Pack quantity		1 pcs.
---------------	--	--------

# OA5209



## Diffuse reflection sensor

OAT-FCKG/T

### Electrical connection

terminals: ...1.5 mm<sup>2</sup>; Cable gland: M16 X 1.5

### Connection

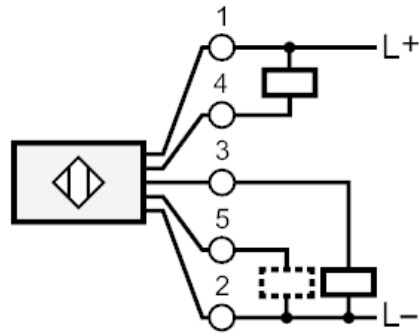

5      Function check output