

O5K500

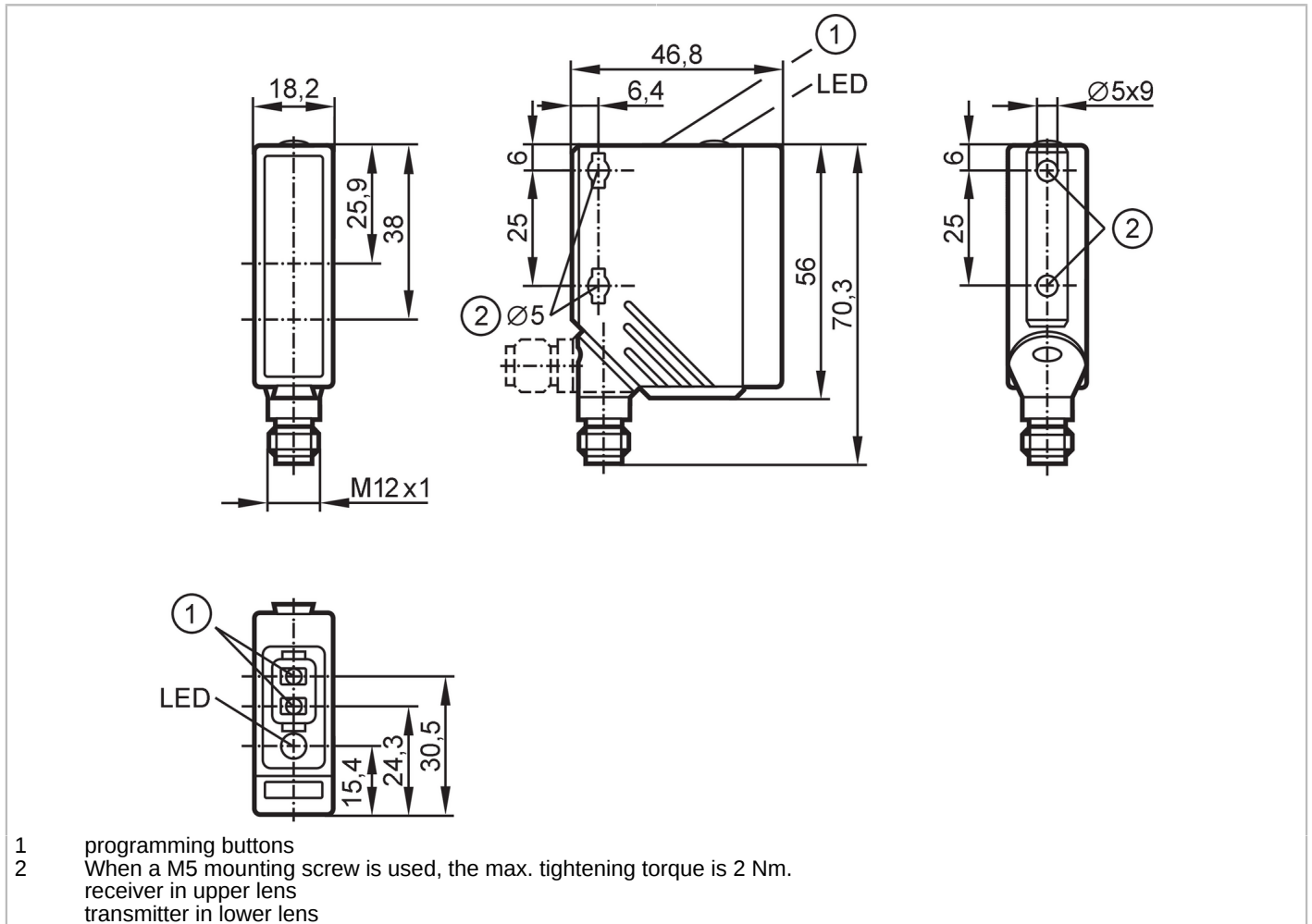

Contrast sensor

O5K-FAKG/US100



Product characteristics	
Type of light	red light; green light; blue light
Housing	rectangular
Application	
Application	High switching frequency for fast processes
Electrical data	
Operating voltage [V]	10...36 DC
Current consumption [mA]	50; ((24 V))
Protection class	II
Reverse polarity protection	yes
Type of light	red light; green light; blue light
Wave length [nm]	625; 525; 465
Outputs	
Electrical design	PNP/NPN; (automatic load detection PNP/NPN)
Output function	light-on/dark-on mode; (programmable)
Max. voltage drop switching output DC [V]	2.5

O5K500



Contrast sensor

O5K-FAKG/US100

Permanent current rating of switching output DC	[mA]	200
Switching frequency DC	[Hz]	10000
Short-circuit protection		yes
Type of short-circuit protection		pulsed
Overload protection		yes

Detection zone		
Range	[mm]	18...22
Max. light spot width	[mm]	1.5
Max. light spot height	[mm]	5

Response times		
Response time	[ms]	< 0.05

Operating conditions		
Ambient temperature	[°C]	-25...60
Protection		IP 67

Tests / approvals		
EMC		EN 60947-5-2
MTTF	[years]	568

Mechanical data		
Weight	[g]	79.5
Housing		rectangular
Dimensions	[mm]	56 x 18.2 x 46.8
Materials		housing: PA; bezel: stainless steel; operator interface: TPU / PC
Lens material		front pane:PMMA
Lens alignment		side lens

Displays / operating elements		
Display	switching status	1 x LED, yellow
Teach function		yes
Electronic lock		yes

Remarks		
Remarks		operating voltage "supply class 2" according to cULus
Pack quantity		1 pcs.

O5K500



Contrast sensor

O5K-FAKG/US100

Electrical connection

Connector: 1 x M12; coding: A; Contacts: 5

