

UGT518

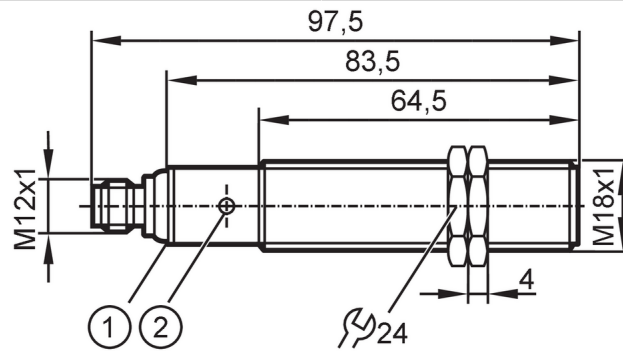

Ultrasonic sensor

UGA02200HOKG/US



- 1 LEDs
- 2 teach button



Product characteristics

Electrical design	NPN
Output function	normally open / closed; (configurable)
Sensing range [mm]	200...2200; (Target: 200 x 200 mm)
Housing	Threaded type
Dimensions [mm]	M18 x 1 / L = 97.5

Electrical data

Operating voltage [V]	10...30 DC; (cULus - Class 2 source required)
Current consumption [mA]	55
Protection class	III
Reverse polarity protection	yes
Power-on delay time [s]	< 0.3
Converter frequency [kHz]	200

Inputs / outputs

Number of inputs and outputs	Number of digital outputs: 2
------------------------------	------------------------------

Outputs

Total number of outputs	2
Electrical design	NPN
Number of digital outputs	2
Output function	normally open / closed; (configurable)
Max. voltage drop switching output DC [V]	2.2
Permanent current rating of switching output DC [mA]	100
Switching frequency DC [Hz]	2
Short-circuit protection	yes
Overload protection	yes

Monitoring range

Sensing range [mm]	200...2200; (Target: 200 x 200 mm)
Blind zone [mm]	200
Angle of aperture cylindrical [°]	14; (±2)

UGT518



Ultrasonic sensor

UGA02200HOKG/US

Max. deviation from the 90° angle sensor/object	[°]	± 4
---	-----	-----

Accuracy / deviations

Temperature compensation		yes
Hysteresis	[%]	< 2
Switch-point drift	[%]	-2...2
Repeatability		1 %
Resolution	[mm]	1
Notes on the accuracy / deviation	The indicated values are reached after a warm-up time of min. 20 minutes	

Operating conditions

Ambient temperature	[°C]	-20...70
Storage temperature	[°C]	-30...80
Protection		IP 67

Tests / approvals

EMC	EN 61000-4-2 ESD	4 kV CD / 8 kV AD
	EN 61000-4-3 HF radiated	3 V/m
	EN 61000-4-4 Burst	2 kV
	EN 61000-4-6 HF conducted	3 V
	EN 55011	class A
Vibration resistance	EN 60068-2-6 Fc	(10-55) Hz 1 mm amplitude, vibration duration 5 min., 30 min. per axis with resonance or 55 Hz
Shock resistance	EN 60068-2-27 Ea	30 g 11 ms half-sine; 3 shocks each in every direction of the 3 coordinate axes
MTTF	[years]	138
UL approval	Ta	-20...70 °C
	voltage supply	Class 2
	File number UL	E174191

Mechanical data

Weight	[g]	101
Housing		Threaded type
Dimensions	[mm]	M18 x 1 / L = 97.5
Thread designation		M18 x 1
Material		stainless steel (1.4404 / 316L); PA; epoxy glass ceramics
Tightening torque	[Nm]	50

Displays / operating elements

Display	Switching status	2 x LED, yellow
	echo	1 x LED, green
Teach function		yes

Accessories

Items supplied	lock nuts: 2 x M18, stainless steel
----------------	-------------------------------------

Remarks

Remarks	cULus - Class 2 source required
Pack quantity	1 pcs.

UGT518



Ultrasonic sensor

UGA02200HOKG/US

Electrical connection

Connector: 1 x M12; coding: A



Connection

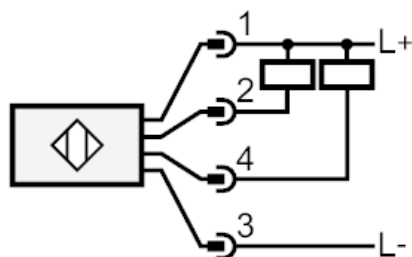



Diagrams and graphs

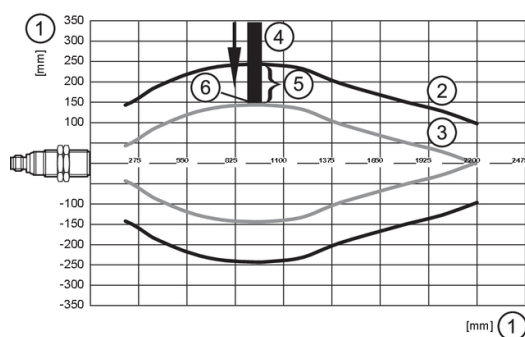
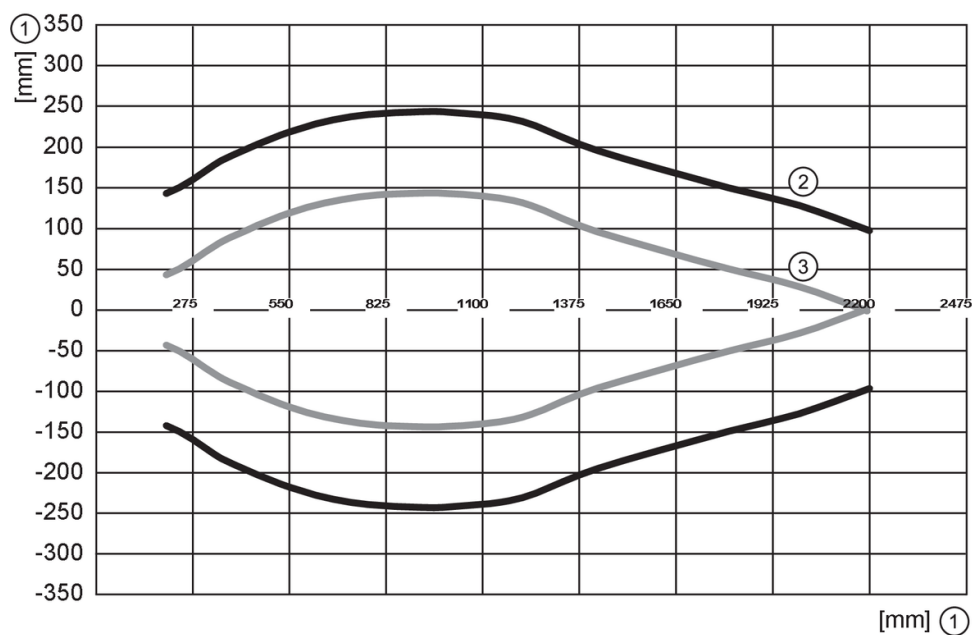

- 1: Distance
- 2: Monitoring range
- 3: switch-on/switch-off graph
- 4: Target 200 x 200 mm
- 5: 50 % of the target in the detection zone
- 6: Set point