

UGR502



Ultrasonic sensor

UGA01600FOKG/US

Article to be discontinued

Discontinuation date: 03/31/2025

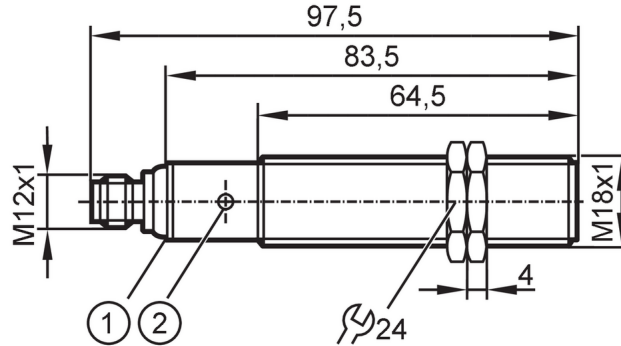

- 1 LEDs
- 2 teach button



Product characteristics

Housing	Threaded type
---------	---------------

Electrical data

Operating voltage	[V]	10...30 DC; (cULus - Class 2 source required)
Current consumption	[mA]	55
Protection class		III
Reverse polarity protection		yes
Power-on delay time	[s]	< 0.3
Converter frequency	[kHz]	230

Inputs / outputs

Number of inputs and outputs	Number of digital outputs: 1
------------------------------	------------------------------

Outputs

Total number of outputs	1	
Electrical design	NPN	
Number of digital outputs	1	
Output function	normally open / closed; (configurable)	
Max. voltage drop switching output DC	[V]	2.2
Permanent current rating of switching output DC	[mA]	100
Switching frequency DC	[Hz]	2
Short-circuit protection		yes
Overload protection		yes

Monitoring range

Sensing range	[mm]	< 1600; (Target: 200 x 200 mm)
Angle of aperture cylindrical	[°]	15; (±2)

Accuracy / deviations

Temperature compensation		yes
Hysteresis	[%]	< 2

UGR502



Ultrasonic sensor

UGA01600FOKG/US

Switch-point drift	[%]	-2...2
Repeatability		1 %
Resolution	[mm]	1
Notes on the accuracy / deviation		The indicated values are reached after a warm-up time of min. 20 minutes

Operating conditions

Ambient temperature	[°C]	-20...70
Storage temperature	[°C]	-30...80
Protection		IP 67

Tests / approvals

EMC	EN 61000-4-2 ESD	4 kV CD / 8 kV AD
	EN 61000-4-3 HF radiated	3 V/m
	EN 61000-4-4 Burst	2 kV
	EN 61000-4-6 HF conducted	3 V
	EN 55011	class A
Vibration resistance	EN 60068-2-6 Fc	(10-55) Hz 1 mm amplitude, vibration duration 5 min., 30 min. per axis with resonance or 55 Hz
Shock resistance	EN 60068-2-27 Ea	30 g 11 ms half-sine; 3 shocks each in every direction of the 3 coordinate axes
MTTF	[years]	145
UL approval	Ta	-20...70 °C
	voltage supply	Class 2
	File number UL	E174191

Mechanical data

Weight	[g]	101
Housing		Threaded type
Dimensions	[mm]	M18 x 1 / L = 97.5
Thread designation		M18 x 1
Material		stainless steel (1.4404 / 316L); PA; epoxy glass ceramics
Tightening torque	[Nm]	50

Displays / operating elements

Display	Switching status	2 x LED, yellow
	echo	1 x LED, green
Teach function		yes

Accessories

Items supplied	lock nuts: 2 x M18, stainless steel
----------------	-------------------------------------

Remarks

Remarks	cULus - Class 2 source required
Pack quantity	1 pcs.

Electrical connection - connector

Connector: 1 x M12; coding: A



Ultrasonic sensor

UGA01600FOKG/US

Connection

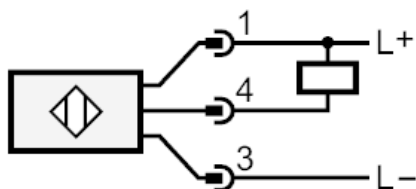

Diagrams and graphs

Response curve

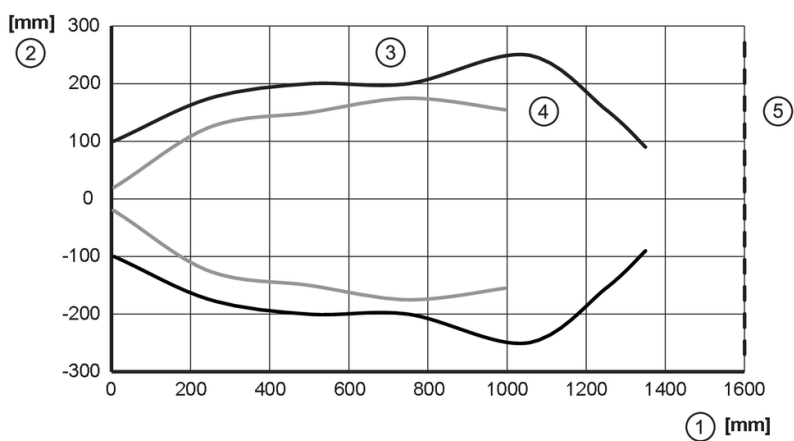

- 1: Distance
- 2: sound beam
- 3: Target 200 x 200 mm
- 4: Target Ø 25 mm
- 5: Reflector