

TW2101

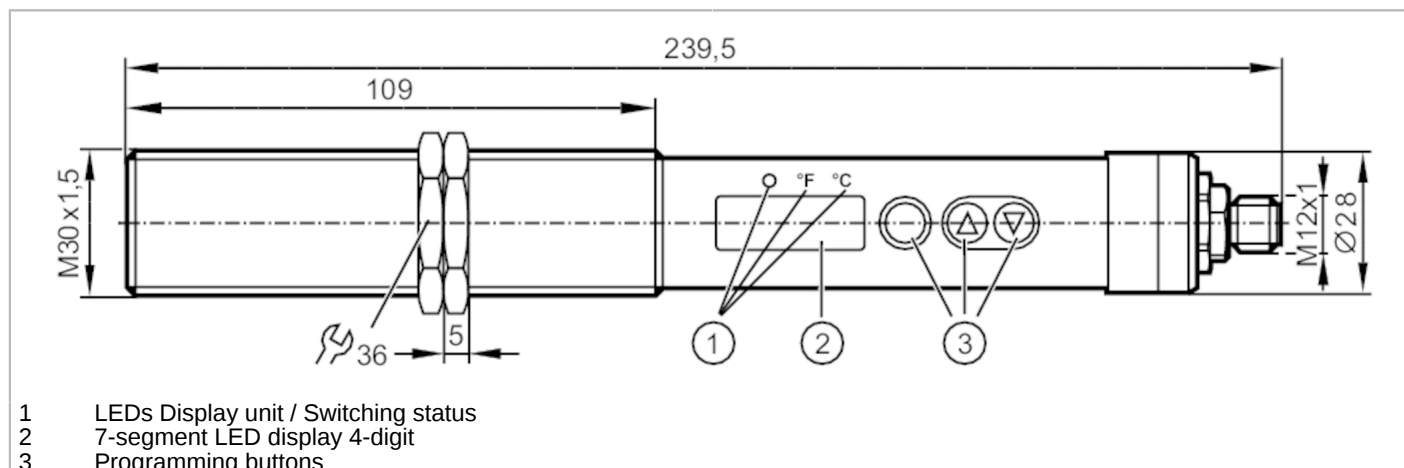

Infrared temperature sensor

TW-100KLBM30-KFDKG/US



Product characteristics	
Number of inputs and outputs	Number of digital outputs: 1; Number of analog outputs: 1
Measuring range	250...1600 °C 482...2912 °F
Communication interface	IO-Link

Application	
Application	tempering temperatures; glass melting; graphite; ceramics; metals; forging; sintering; heat treatment; rolling

Electrical data	
Operating voltage [V]	18...32 DC; (to SELV/PELV)
Current consumption [mA]	< 50
Min. insulation resistance [MΩ]	100; (50 V DC)
Protection class	III
Reverse polarity protection	yes
Power-on delay time [s]	< 1

Inputs / outputs	
Number of inputs and outputs	Number of digital outputs: 1; Number of analog outputs: 1

Inputs	
Test input	type 3 (IEC 61131-2)

Outputs	
Total number of outputs	2
Output signal	switching signal; analog signal; IO-Link; (configurable)
Electrical design	PNP
Number of digital outputs	1
Output function	normally open / closed; (configurable)
Max. voltage drop switching output DC [V]	2.5
Permanent current rating of switching output DC [mA]	150
Number of analog outputs	1
Analog current output [mA]	4...20

TW2101



Infrared temperature sensor

TW-100KLBM30-KFDKG/US

Max. load	[Ω]	500
Short-circuit protection		yes
Type of short-circuit protection		yes (non-latching)
Short-circuit proof		yes
Overload protection		yes

Monitoring range

Wave length range	[μm]	1...1.7
-------------------	------	---------

Measuring/setting range

Measuring range	250...1600 °C	482...2912 °F
Set point SP	251...1600 °C	484...2912 °F
Reset point rP	250...1599 °C	482...2910 °F
Analog start point	250...1400 °C	482...2552 °F
Analog end point	450...1600 °C	842...2912 °F
In steps of	1 °C	1 °F

Resolution

Resolution of switching output	[K]	1
Resolution of analog output	[K]	0.2; (+ 0.03 % of the set measuring span)
Resolution of display	[K]	1

Accuracy / deviations

Accuracy	[K]	< ± 0,5 %; (of measured value, min. 4 K (degree of emission = 1, T = 23 °C))
Repeatability	[K]	1

Reaction times

Response time	[ms]	2; (T > 600 °C)
---------------	------	-----------------

Software / programming

Adjustment of the switch point	Programming buttons
Parameter setting options	Analog range; normally open / closed; switch-on/switch-off delay; Damping; Peakhold; emissivity; simulation function

Interfaces

Communication interface	IO-Link	
Transmission type	COM2 (38,4 kBaud)	
IO-Link revision	1.1	
SDCI standard	IEC 61131-9	
Profiles	Smart Sensor - SSP 0	Generic Profiled Sensor
	Function	Device identification
	Function	Process data variable
	Function	Device diagnosis
SIO mode	yes	
Required master port class	A	
Process data analog	16	
Process data binary	1	
Min. process cycle time	[ms]	3.6
Supported DeviceIDs	Type of operation	DeviceID
	default	717

TW2101



Infrared temperature sensor

TW-100KLBM30-KFDKG/US

Operating conditions		
Ambient temperature	[°C]	0...65
Storage temperature	[°C]	-20...80
Max. relative air humidity	[%]	95; (non condensing)
Protection		IP 65
Tests / approvals		
EMC	DIN EN 61000-6-2	
	DIN EN 61000-6-4	
Shock resistance	DIN EN 60068-2-27	30 g (11 ms)
Vibration resistance	DIN EN 60068-2-6	5 g (10...2000 Hz)
MTTF	[years]	70.6
Mechanical data		
Weight	[g]	509
Housing		Threaded type
Dimensions	[mm]	M30 x 1.5 / L = 239.5
Thread designation		M30 x 1.5
Material		threaded sleeve: stainless steel (1.4305 / 303); operator interface: polyester
Lens material		front lens:tempered optical glass
Displays / operating elements		
Display	Display unit	2 x LED, yellow
	Switching status	1 x LED, yellow
	Function display	7-segment LED display, 4-digit
	Measured values	7-segment LED display, 4-digit
	Setting aid	LED pilot light, green
Operating elements	3	Pushbuttons
Accessories		
Items supplied		lock nuts: 2
Remarks		
Remarks		Use a screened cable to protect infrared temperature sensors from interference. The screen must be connected to the housing of the sensor via the connector.
Pack quantity		1 pcs.

TW2101



Infrared temperature sensor

TW-100KLBM30-KFDKG/US

Electrical connection

Connection

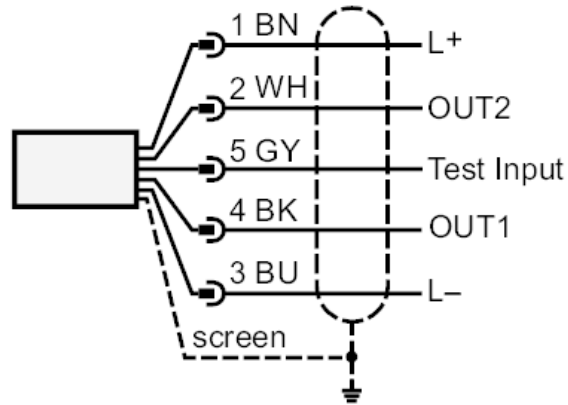

OUT1: Switching output / IO-Link
OUT2: analog output
Core colors :
BK = black
BN = brown
BU = blue
GY = grey
WH = white

Diagrams and graphs

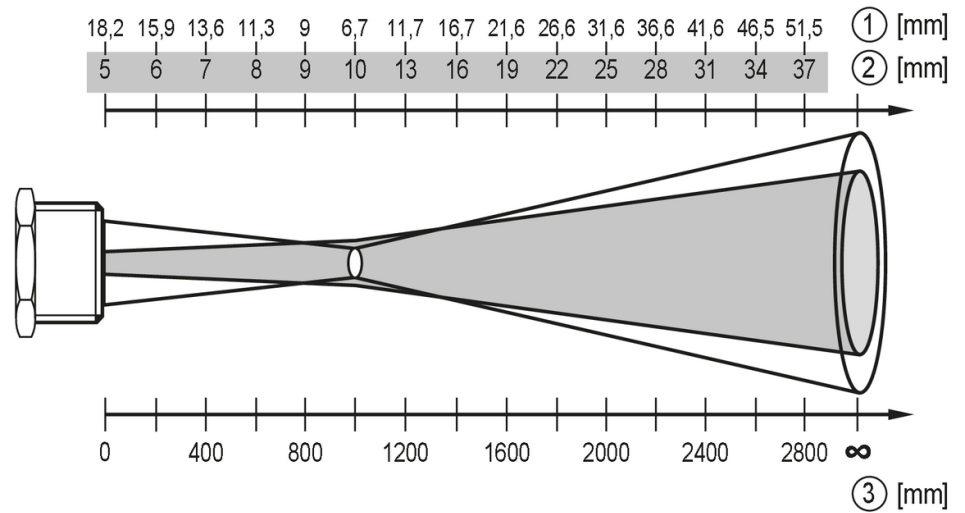

- 1 diameter of the measured spot
- 2 Diameter LED pilot light
- 3 measuring distance