

TP2007

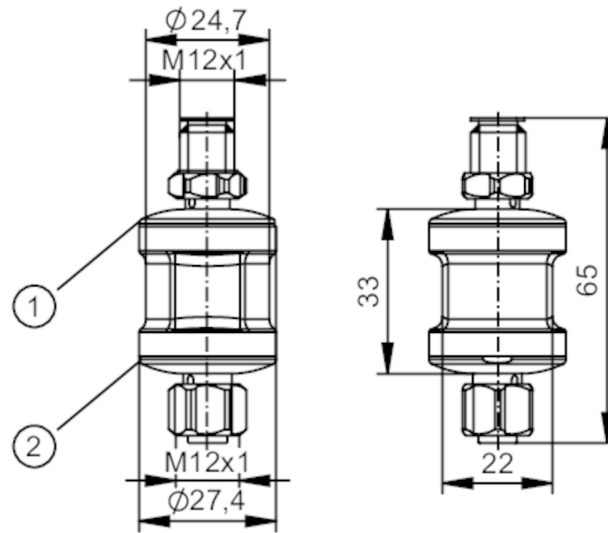

Temperature plug for hygienic applications

TP-CDC-AFZVG/US/



- 1 LED switching status indication
2 LED voltage indication



Product characteristics

Number of inputs and outputs	Number of digital outputs: 1; Number of analog outputs: 1	
Measuring range	-100...300 °C	-148...572 °F
Communication interface	IO-Link	

Application

Special feature	gold-plated contacts
Application	for Pt100 and Pt1000 measuring elements

Electrical data

Operating voltage [V]	18...32 DC
Protection class	III
Reverse polarity protection	yes
Overtoltage category	II
Power-on delay time [s]	2
Integrated watchdog	yes

Inputs / outputs

Number of inputs and outputs	Number of digital outputs: 1; Number of analog outputs: 1
------------------------------	---

Outputs

Total number of outputs	2
Output signal	analog signal; IO-Link; switching signal; (configurable)
Electrical design	PNP/NPN
Number of digital outputs	1
Output function	normally open / closed; (configurable)
Max. voltage drop switching output DC [V]	2
Permanent current rating of switching output DC [mA]	100

TP2007



Temperature plug for hygienic applications

TP-CDC-AFZVG/US/

Number of analog outputs	1	
Analog current output [mA]	4...20	
Max. load [Ω]	(Ub-13,5)/0,0215	
Short-circuit protection	yes	
Type of short-circuit protection	not locked in place	
Overload protection	yes	
Measuring/setting range		
Measuring range	-100...300 °C	-148...572 °F
Factory setting	0...100 °C	
Resolution of analog output [K]	0.017; (MS: -10...150 °C)	
Accuracy / deviations		
Precision analog output [K]	$\pm 0,1$; (MS: -10...150 °C) ; or $\pm (0,067 \% MS)$	
Precision IO-Link [K]	$\pm 0,05$	
Temperature coefficient analog output [% of the span / 10 K]	< 0,1	
Temperature coefficient IO-Link [% of the span / 10 K]	< 0,06	
Reaction times		
Max. measuring/display cycle [ms]	350	
Software / programming		
Parameter setting options	scaling of the analog output; calibration adjustment; hysteresis / window; switching logic; simulation mode	
Interfaces		
Communication interface	IO-Link	
Transmission type	COM2 (38,4 kBaud)	
IO-Link revision	1.1.3	
Profiles	Smart Sensor - SSP 3.1	Measuring Sensor
	BLOB	Binary Large Object transfer
	Common - I&D	Identification and Diagnosis
	Function	ProductURI
Min. process cycle time [ms]	3.2	
IO-Link resolution temperature [K]	0.01	
Supported DeviceIDs	Type of operation	DeviceID
	default	1297
Operating conditions		
Ambient temperature [°C]	-25...80	
Storage temperature [°C]	-40...85	
Max. relative air humidity [%]	90; (non condensing)	
Max. height above sea level [m]	2000	
Protection	IP 68; IP 69K	
Degree of soiling	3	

TP2007



Temperature plug for hygienic applications

TP-CDC-AFZVG/US/

Tests / approvals		
EMC	DIN EN 61000-6-2	if frequencies above 40 MHz occur, the housing must be grounded
	DIN EN 61000-6-3	
Shock resistance	DIN EN 68000-2-27	50 g (11 ms)
Vibration resistance	DIN EN 60068-2-6	20 g (10...2000 Hz)
MTTF [years]		462
Mechanical data		
Weight [g]		53.9
Housing		tubular
Dimensions [mm]		Ø 27.4 / L = 65
Material		LED: PA; housing: stainless steel (1.4404 / 316L)
Sealing material		FKM
Displays / operating elements		
Display	status	1 x LED, green
	Switching status	1 x LED, orange
Remarks		
Remarks		MS = set measuring span
Pack quantity		1 pcs.
Electrical connection		
Connector: 1 x M12; coding: A; Moulded body: TPU (urethane); Locking: stainless steel (1.4404 / 316L); sealing: FKM; Contacts: gold-plated		
		

TP2007



Temperature plug for hygienic applications

TP-CDC-AFZVG/US/

Connection

