

TSM501

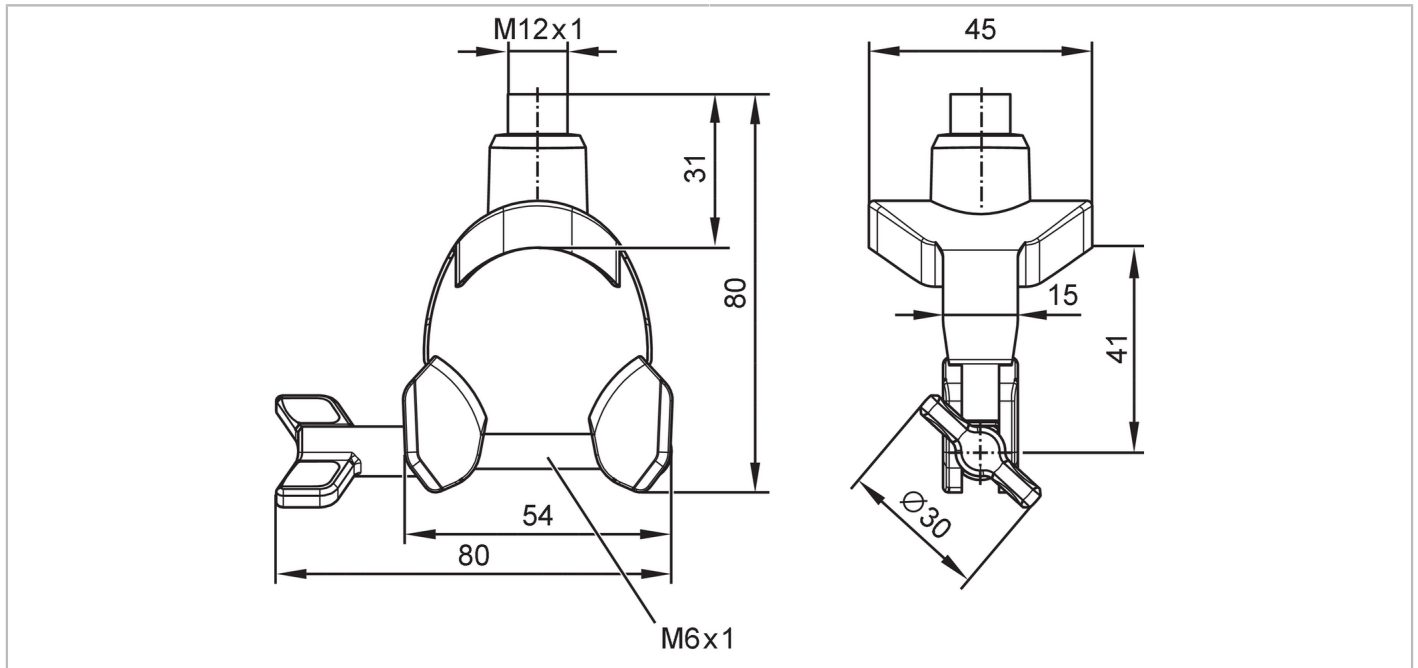

Temperature cable sensor with bolt-on sensor

TSM032K2PCXX/US/



Product characteristics		
Measuring range	-25...160 °C	-13...320 °F
Process connection	bolt-on sensor DN32 (Ø 32...36 mm)	
Application		
Special feature	gold-plated contacts	
Measuring element	1 x Pt 1000; (to DIN EN 60751, class A)	
Installation	Contact sensor for solid bodies; clamp-on solution	
Electrical data		
Protection class	III	
Overvoltage category	II	
Measuring/setting range		
Measuring range	-25...160 °C	-13...320 °F
Accuracy / deviations		
Accuracy	[K]	$\pm (0,15 K + 0,002 \times T)$; (ambient temperature influence on the accuracy: $0,02 \times (T_a - T)$)
Reaction times		
Dynamic response T05 / T09	[s]	7,5 / 25; (reference values for moving water : (> 0,4 m/s))
Operating conditions		
Ambient temperature	[°C]	-25...80
Max. relative air humidity	[%]	90; (non condensing)
Max. height above sea level	[m]	2000
Protection		IP 69K
Degree of soiling		3
Tests / approvals		
MTTF	[years]	22831

TSM501



Temperature cable sensor with bolt-on sensor

TSM032K2PCXX/US/

Mechanical data	
Weight [g]	163.6
Design	Surface temperature probe
Dimensions [mm]	80 x 80 x 45
Material	Mounting clamp: stainless steel (1.4404 / 316L); housing: PPSU; Gasket: FKM
Process connection	bolt-on sensor DN32 (Ø 32...36 mm)
Remarks	
Remarks	Ta = Ambient temperature T = Process temperature
Pack quantity	1 pcs.

Electrical connection

Connector: 1 x M12; coding: A; Contacts: gold-plated



Connection

