

TM4931

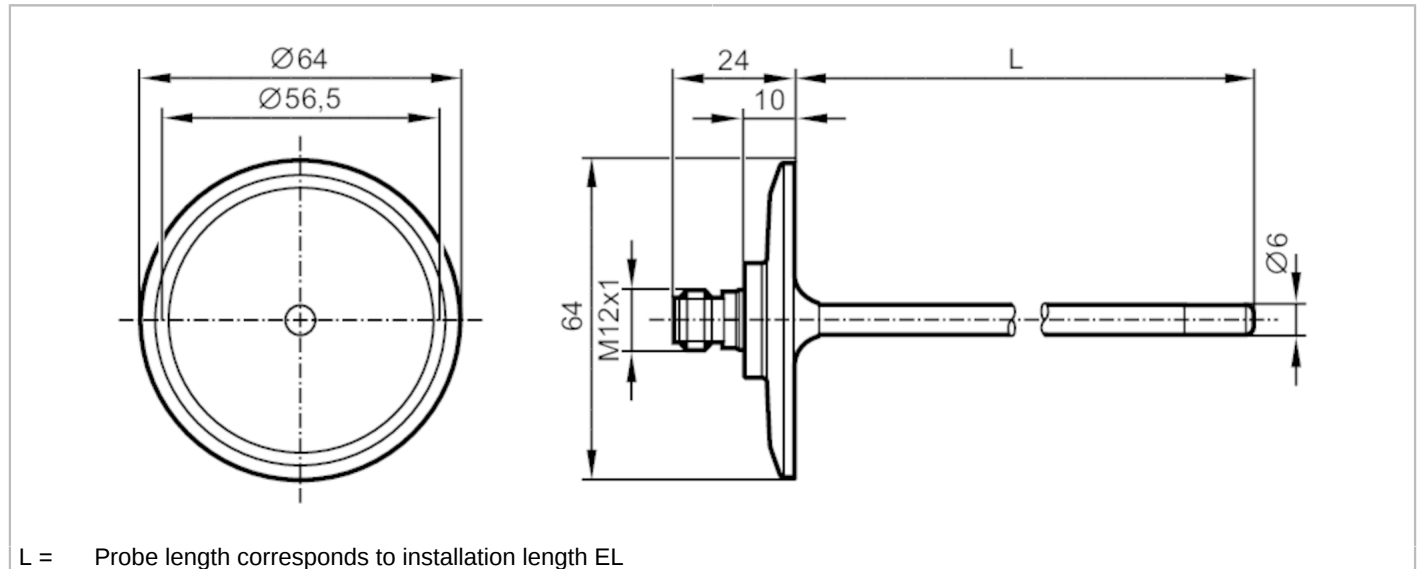

Temperature sensor with process connection

TM-100KFEC02- /US/



L = Probe length corresponds to installation length EL



EC 1935/2004

EHEDG Certified

FCM



Product characteristics		
Measuring range	-40...150 °C	-40...302 °F
Process connection	Clamp DN50 (2") DIN 32676 (ISO 2852)	
Installation length EL [mm]	100	
Application		
Special feature	gold-plated contacts	
Measuring element	1 x Pt 100; (to DIN EN 60751, class A)	
Application	hygienic systems	
Media	liquids and gases	
Pressure rating	25 bar	2.5 MPa
Minimum installation depth [mm]	15	
Electrical data		
Protection class	III	
Measuring/setting range		
Probe length L [mm]	100	
Measuring range	-40...150 °C	-40...302 °F
Accuracy / deviations		
Accuracy [K]	± (0,15 K + 0,002 x t)	
Reaction times		
Dynamic response T05 / T09 [s]	1 / 3; (according to DIN EN 60751)	
Operating conditions		
Ambient temperature [°C]	-25...80	
Storage temperature [°C]	-40...100	
Protection	IP 68; IP 69K	
Tests / approvals		
Shock resistance	DIN EN 60068-2-27	50 g (11 ms)
Vibration resistance	DIN EN 60068-2-6	10 g (10...2000 Hz)

TM4931



Temperature sensor with process connection

TM-100KFEC02- /US/

MTTF [years] 22831

Mechanical data

Weight [g]	234.5
Housing	tubular
Dimensions [mm]	Ø 64 / L = 124
Material	stainless steel (1.4404 / 316L)
Materials (wetted parts)	stainless steel (1.4404 / 316L) electropolished
Process connection	Clamp DN50 (2") DIN 32676 (ISO 2852)
Surface characteristics Ra/Rz of the wetted parts	Ra < 0.8 µm
Probe diameter [mm]	6
Installation length EL [mm]	100

Remarks

Remarks	cULus - Class 2 source required The values for accuracy apply to flowing water.
Pack quantity	1 pcs.

Electrical connection

Connector: 1 x M12; coding: A; Contacts: gold-plated



Connection

