

TA2812

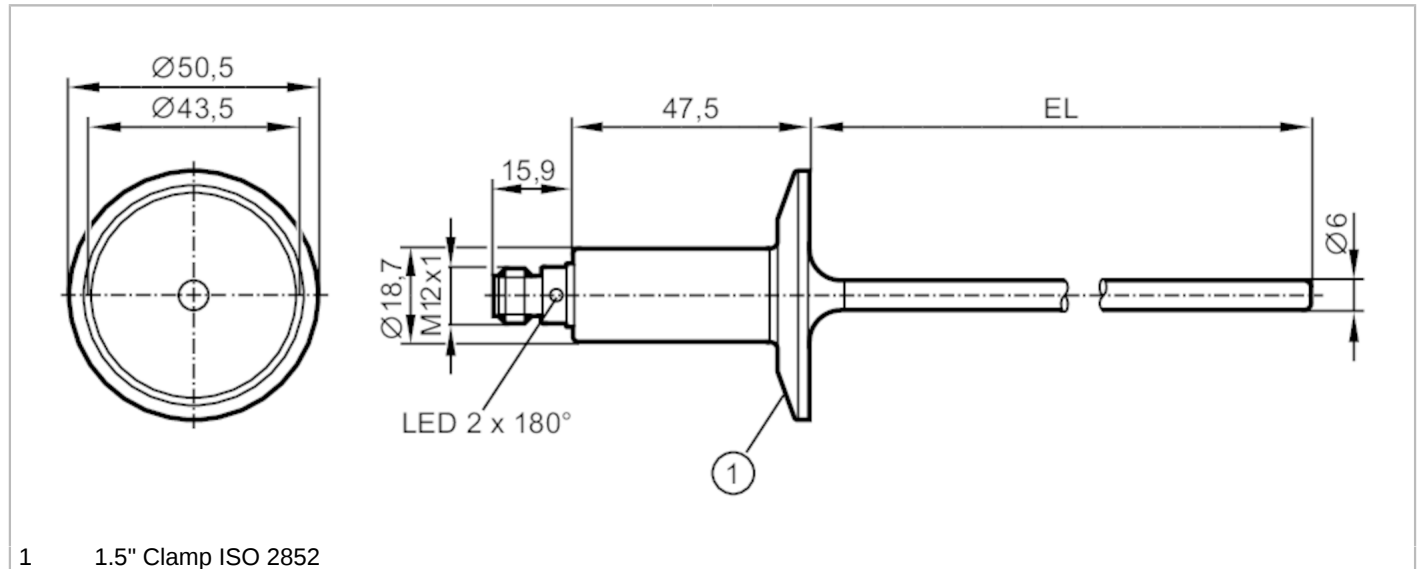

Temperature transmitter

TA-050CLEC01-- /US



1 1.5" Clamp ISO 2852



Product characteristics

Number of inputs and outputs	Number of analog outputs: 1	
Measuring range [°C]	-50...200	
Communication interface	IO-Link	
Process connection	Clamp DN25...DN40 (1...1,5") DIN 32676 (ISO 2852)	
Installation length EL [mm]	50	

Application

Measuring element	1 x Pt 1000; (to DIN EN 60751, class A)	
Media	liquids and gases	
Pressure rating	100 bar	10 MPa
Vacuum resistance	-1000 mbar	-0.1 MPa
MAWP (for applications according to CRN) [bar]	55	

Electrical data

Operating voltage [V]	18...32 DC; (cULus - Class 2 source required)	
Current consumption [mA]	< 50	
Protection class	III	
Reverse polarity protection	yes	
Power-on delay time [s]	2	

Inputs / outputs

Number of inputs and outputs	Number of analog outputs: 1
------------------------------	-----------------------------

Outputs

Total number of outputs	1
Output signal	analog signal; IO-Link; (configurable)
Number of analog outputs	1
Analog current output [mA]	4...20
Max. load [Ω]	250; ((18...19 V); 19...32 V: 300 Ω)
Short-circuit protection	yes

TA2812



Temperature transmitter

TA-050CLEC01-- /US

Overload protection		yes
Measuring/setting range		
Probe length L	[mm]	50
Measuring range	[°C]	-50...200
Factory setting		0...200 °C
Resolution		
Resolution of analog output	[K]	0.04
Accuracy / deviations		
Precision analog output	[K]	± 0,3 + (± 0,1 % MS)
Temperature coefficient [% of the span / 10 K]		0,1; (In case of deviation from the reference condition 25 ± 5 °C)
Reaction times		
Dynamic response T05 / T09	[s]	< 0,5 / < 2
Interfaces		
Communication interface		IO-Link
Transmission type		COM2 (38,4 kBaud)
IO-Link revision		1.1
Profiles	Smart Sensor - SSP 0	Generic Profiled Sensor
	Function	Device identification
	Function	Process data variable
Min. process cycle time	[ms]	2.3
Supported DeviceIDs	Type of operation	DeviceID
	default	446
Operating conditions		
Ambient temperature	[°C]	-25...80
Note on ambient temperature		at medium temperature: < 160 °C -25...60 °C at medium temperature: < 200 °C
Storage temperature	[°C]	-40...100
Protection		IP 67; IP 68; IP 69K
Tests / approvals		
EMC	DIN EN 61000-6-2	
	DIN EN 61000-6-3	
Shock resistance	DIN IEC 68-2-27	50 g (11 ms)
Vibration resistance	DIN IEC 68-2-6	10 g (10...2000 Hz)
MTTF	[years]	232
Note on approval		Factory certificate available as download at www.factory-certificate.ifm
UL approval	UL approval number	K002
Mechanical data		
Weight	[g]	229.6
Housing		tubular
Dimensions	[mm]	Ø 50.5 / L = 113.4
Material		stainless steel (1.4404 / 316L); PEI; FKM
Materials (wetted parts)		stainless steel (1.4404 / 316L) electropolished
Process connection		Clamp DN25...DN40 (1...1,5") DIN 32676 (ISO 2852)

TA2812



Temperature transmitter

TA-050CLEC01- - /US

Surface characteristics Ra/Rz of the wetted parts		Ra < 0.8 µm
Probe diameter	[mm]	6
Installation length EL	[mm]	50

Remarks

Remarks	MS = set measuring span The values for accuracy apply to flowing water.
Pack quantity	1 pcs.

Electrical connection

Connector: 1 x M12; coding: A; Contacts: 4



Connection

