

SV4151

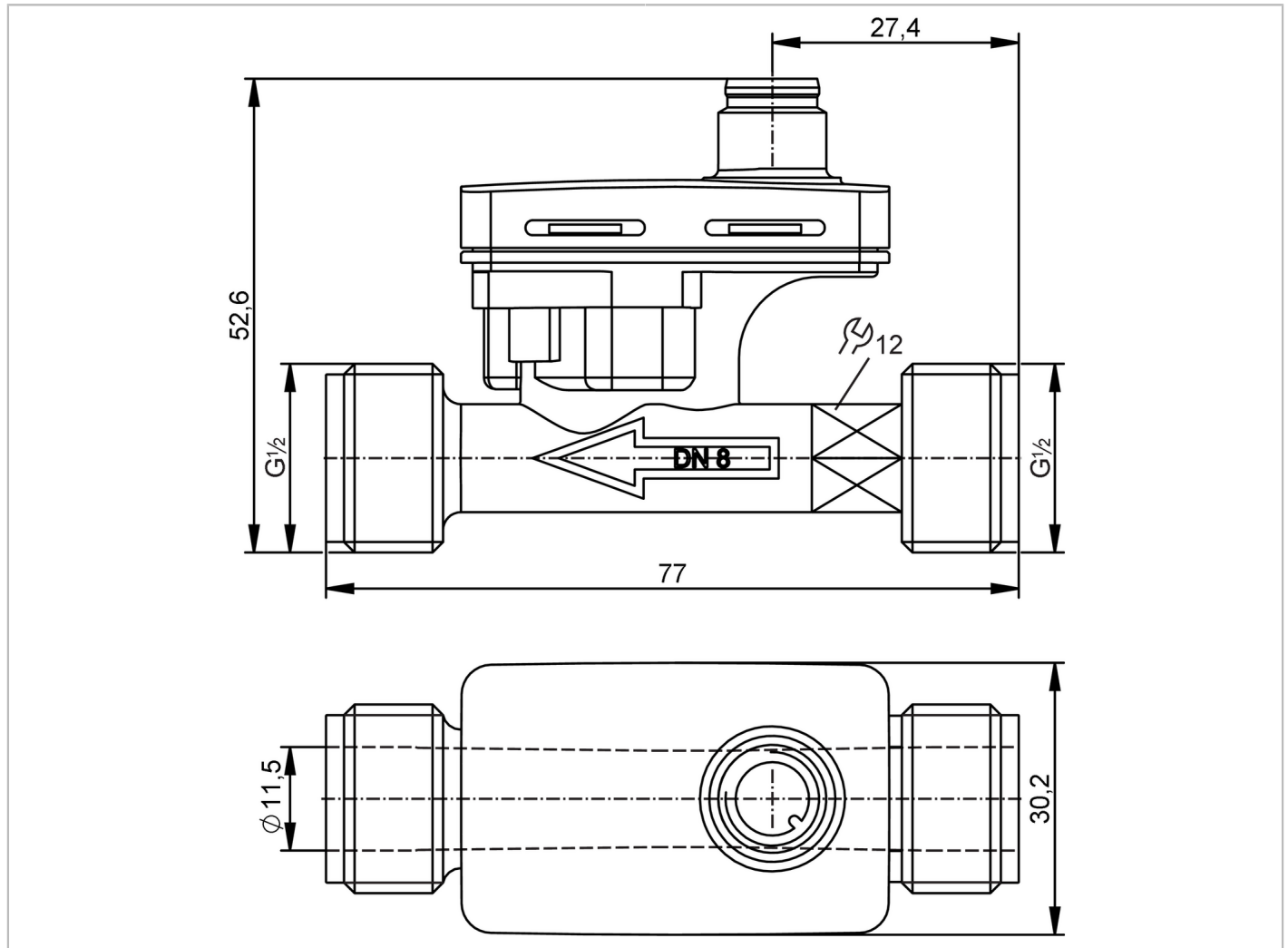

Vortex flow meter

SVR12XGXD0KG/US



Product characteristics

Number of inputs and outputs	Number of analog outputs: 1	
Measuring range	0.9...15 l/min	0.133...2.21 m/s
Process connection	threaded connection G 1/2 external thread DN8	

Application

Special feature	gold-plated contacts	
Measuring element	1 x Pt 1000; (to DIN EN 60751, class B)	
Application	for industrial applications	
Installation	connection to pipe by means of an adapter	
Media	ultra-pure water; water; glycol solutions; Coolants	
Medium temperature [°C]	-15...125	
Min. burst pressure	25 bar	2.5 MPa
Note on min. burst pressure	125 °C	
Pressure rating	16 bar	1.6 MPa
Note on pressure rating	≤ 90 °C	

Electrical data

Operating voltage [V]	8...33 DC
-----------------------	-----------

SV4151



Vortex flow meter

SVR12XGXD0KG/US

Current consumption	[mA]	< 5
Min. insulation resistance	[MΩ]	100; (500 V DC)
Protection class		III
Power-on delay time	[s]	< 2
Measuring principle		Vortex

Inputs / outputs

Number of inputs and outputs	Number of analog outputs: 1
------------------------------	-----------------------------

Outputs

Total number of outputs	1
Output signal	analog signal
Number of analog outputs	1
Analog current output	[mA] 4...20
Max. load	[Ω] < (U _b - 8 V) / 20 mA; U _b = 24 V: 800

Measuring/setting range

Measuring range	0.9...15 l/min	0.133...2.21 m/s
-----------------	----------------	------------------

Temperature monitoring

Internal heating temperature probe	1 K/mW
Measuring range	[°C] -15...125

Accuracy / deviations

Flow monitoring

Accuracy (in the measuring range)	water	Q < 50 % MEW: < 1 % MEW / Q > 50 % MEW: < 2 % MEW
	glycol solutions (35%)	2 > v < 6 cSt: ± 5% MEW / 6 > v < 15 cSt: ± 10% MEW
Repeatability	0,2; (% of the final value)	

Temperature monitoring

Accuracy	[K] ± 0,3 ± 0,005 x T
----------	-----------------------

Reaction times

Flow monitoring

Response time	[s] 0.34; (T09)
---------------	-----------------

Temperature monitoring

Dynamic response T05 / T09	[s] < 10 / < 30
----------------------------	-----------------

Operating conditions

Ambient temperature	[°C] -15...85
Note on ambient temperature	Medium temperature > 0 °C: -40...85
Storage temperature	[°C] -40...85
Protection	IP 65
Cavitation	P(absolute) discharge / P(difference) > 5.5 to avoid cavitation

Tests / approvals

EMC	EN IEC 61326-1:2021	
Shock resistance	DIN EN 60068-2-27	30 g (11 ms)
Vibration resistance	DIN EN 60068-2-6	with water / 10...61 Hz 1 mm
		with water / 61...2000 Hz 2 g

SV4151



Vortex flow meter

SVR12XGXD0KG/US

MTTF	[years]	395.9
UL approval	File number UL	E364788
Pressure equipment directive	sound engineering practice; can be used for group 2 fluids; group 1 fluids on request	

Mechanical data		
Weight	[g]	68.95
Housing		rectangular
Dimensions	[mm]	77 x 30.2 x 52.6
Material		Housing: PPS 40% glass fiber; electronics: PC 10% glass fiber
Materials (wetted parts)		sensor: PPSU; Pipe section: PPS 40% glass fiber; sealing: EPDM
Tightening torque	[Nm]	12
Process connection		threaded connection G 1/2 external thread DN8

Remarks	
Remarks	MW = Measured value MEW = Final value of the measuring range
Pack quantity	1 pcs.

Electrical connection

Connector: 1 x M12; coding: A; Contacts: 4, gold-plated



Connection

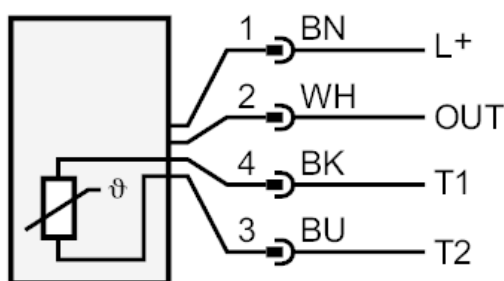

OUT: analog output
T1 / T2: Pt1000
Colors to DIN EN 60947-5-2
Core colors :
BK = black
BN = brown
BU = blue
WH = white

SV4151



Vortex flow meter

SVR12XGXD0KG/US

Other data

determination using the compensation value and the response threshold for glycol-water mixtures

determination of the compensation value Q0	[l/min]	$0.938 \times (I - 4mA) - 0.22v + 0.22$
determination of the response threshold Qmin	[l/min]	$- 0.1 + v$
v =	kinematische Viskosität	

Diagrams and graphs

Pressure rating

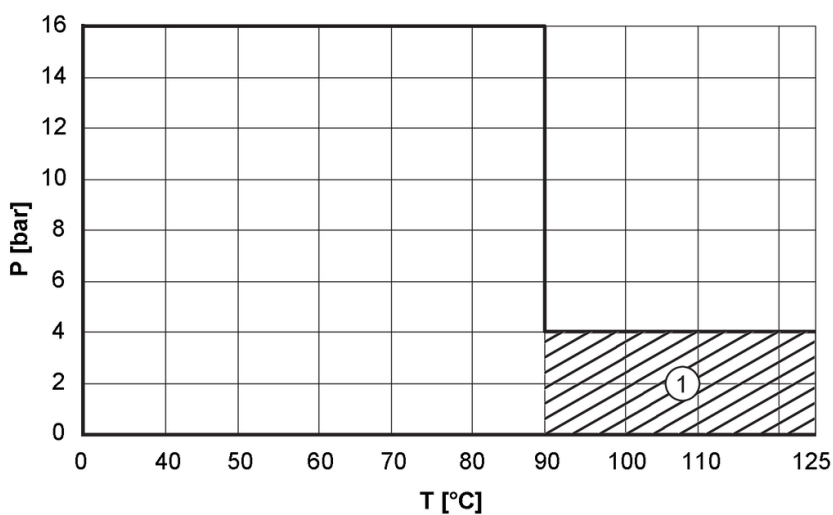

P [bar] = pressure
T [°C] = temperature
1 = permanent

Pressure loss

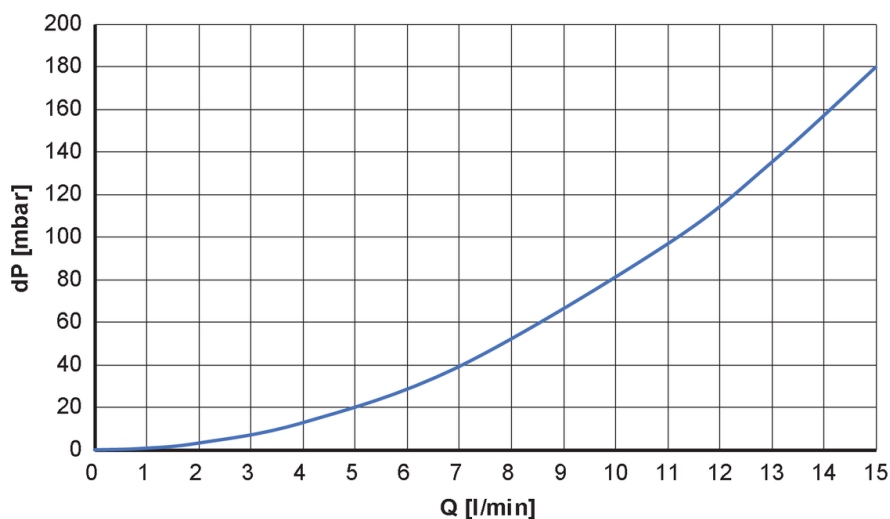

dP [mbar] = Pressure loss
Q [l/min] = volumetric flow quantity