

SMF650

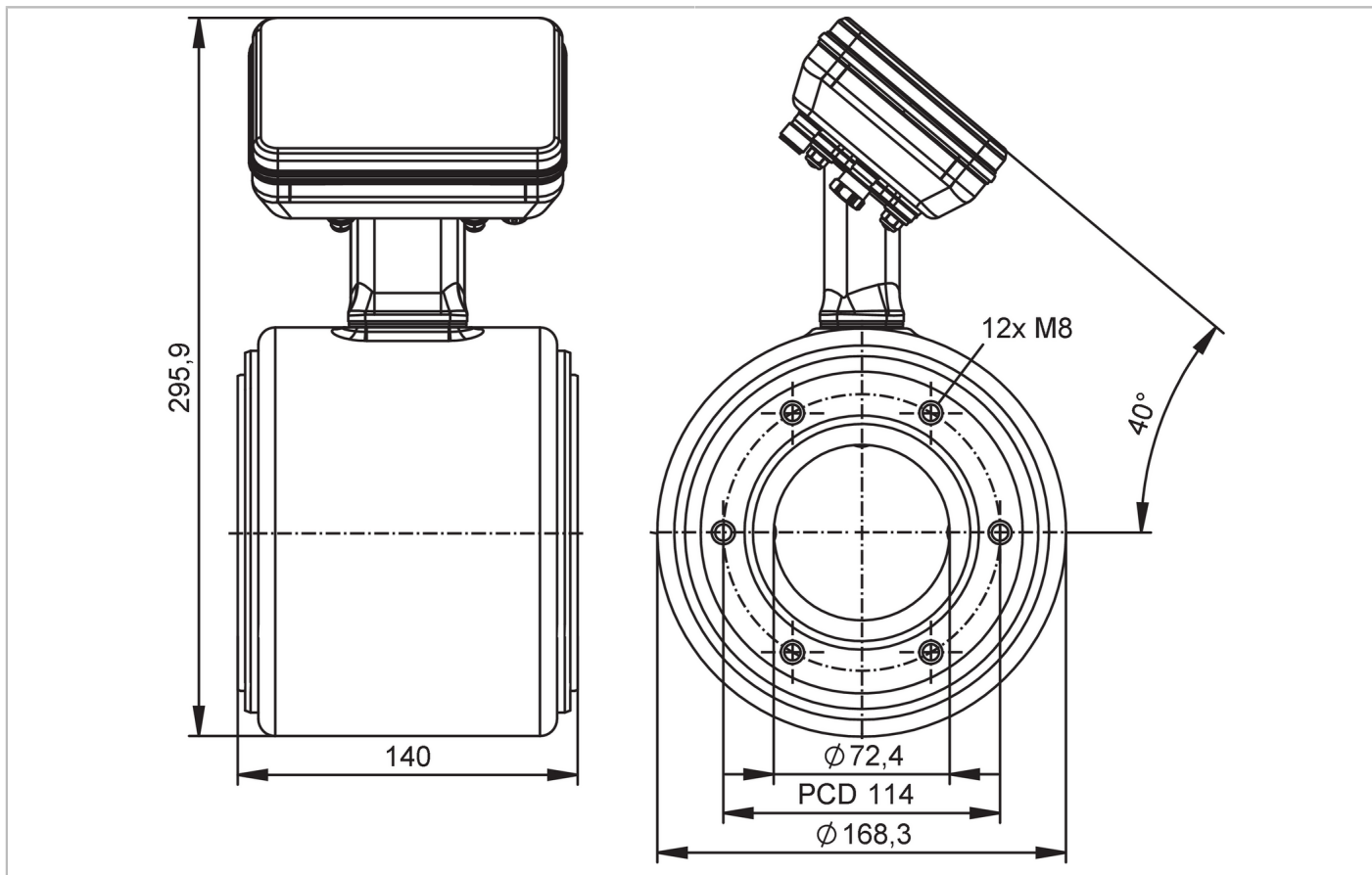

Magnetic-inductive flow meter

SMG80KGFFRKG/UST



EC 1935/2004

FCM



Product characteristics

Measuring range	30...3000 l/min	1.8...180 m ³ /h	7.93...792.6 gpm	0.33...32.8 ft/s
Nominal diameter	DN80 (3")			
Process connection	ifm-specific device flange			

Application

Special feature	gold-plated contacts			
Application	food and beverage industry			
Media	Conductive liquids; water; water-based media			
Note on media	food products such as beer, milk, fruit juices, soft drinks, ketchup, yogurt, yogurt toppings, ice cream			
	conductivity: $\geq 5 \mu\text{S/cm}$			
Medium temperature [°C]	-20...150			
Min. burst pressure	37.5 bar	543.75 psi	3.75 MPa	
Pressure rating	25 bar	362.5 psi	2.5 MPa	

Electrical data

Operating voltage [V]	18...32 DC			
Current consumption [mA]	250; (24V)			
Protection class	III			
Reverse polarity protection	yes			
Power-on delay time [s]	< 5			

SMF650



Magnetic-inductive flow meter

SMG80KGFFRKG/UST

Measuring principle	magnetic-inductive			
Inputs / outputs				
Total number of inputs and outputs	2			
Inputs				
Inputs	OUT2	external totalizer reset		
Outputs				
Total number of outputs	2			
Output signal	OUT1	pulse signal; totalizer switching signal; diagnostic signal; IO-Link		
	OUT2	analog signal; pulse signal; totalizer switching signal; diagnostic signal		
Electrical design	PNP/NPN			
Pulse output	flow rate meter			
Short-circuit protection	yes			
Type of short-circuit protection	yes (non-latching)			
Overload protection	yes			
Analog				
Number of analog outputs	1			
Analog current output [mA]	4...20; (skalierbar)			
Max. load [Ω]	500			
Resolution of analog output	0.38 μA			
Digital				
Number of digital outputs	2			
Max. voltage drop switching output DC [V]	2			
Permanent current rating of switching output DC [mA]	100			
Switching frequency DC [Hz]	0...10000			
Measuring/setting range				
Measuring range	30...3000 l/min	1.8...180 m³/h	7.93...792.6 gpm	0.33...32.8 ft/s
Note on factory setting	0...45,0 m³/h			
Analog start point ASP	-3000...2400 l/min	-180...144 m³/h	-972.6...778.08 gpm	-32.8...26.24 ft/s
Analog end point AEP	-2400...3000 l/min	-144...180 m³/h	-778.08...972.6 gpm	-26.24...32.8 ft/s
Low flow cut-off LFC	0...2400 l/min	0...144 m³/h	0...778.08 gpm	0...26.24 ft/s
Pulse length [s]	0.00005...2			
Pulse value	0.005...99999000 l			
Temperature monitoring				
Measuring range	-20...150 °C		-4...302 °F	
Analog start point	-20...116 °C		-4...240.8 °F	
Analog end point	14...150 °C		57.2...302 °F	
Conductivity monitoring				
Measuring range [μS/cm]	100...100000			
Analog start point [μS/cm]	0...80000			
Analog end point [μS/cm]	20000...100000			

SMF650



Magnetic-inductive flow meter

SMG80KGFFRKG/UST

Accuracy / deviations		
Volumetric flow monitoring		
Accuracy (under reference conditions)	with optional factory calibration (availability is being planned)	$\pm (0,2 \% MW + 2 \text{ mm/s})$
	standard	$\pm (0,5 \% MW + 1,5 \text{ mm/s})$
Repeatability		0,1% MW
Temperature monitoring		
Accuracy	[K]	$\pm 1 (v > 0,5 \text{ m/s})$
Repeatability	[K]	$\pm 0,5 (v > 0,5 \text{ m/s})$
Conductivity monitoring		
Accuracy (in the measuring range)	in the range of 100...20000 $\mu\text{S/cm}$	$\pm 10\% MW$
	in the range of 20000...100000 $\mu\text{S/cm}$	$\pm 20\% MW$
Repeatability		$\pm 5\% MW$
Reaction times		
Volumetric flow monitoring		
Response time	[s]	< 0.3
Damping process value dAP	[s]	0...5
Temperature monitoring		
Response time	[s]	< 3; (v > 0,5 m/s)
Conductivity monitoring		
Response time	[s]	< 2
Software / programming		
Diagnostic functions		direction of flow detection; liquid detection
Interfaces		
Communication interface		IO-Link
Transmission type		COM3 (230,4 kBaud)
IO-Link revision		1.1.3
SDCI standard		IEC 61131-9
Profiles	Smart Sensor - SSP 4.3.4	Measuring and Switching Sensor, floating point, 4 channel
	BLOB	Binary Large Object transfer
	Common - I&D	Identification and Diagnosis
	Extension	Sensor Control Wide
	Extension	Quantity detection, switches when value exceeds the setpoint
	Function	Locator
	Function	ProductURI
SIO mode		yes
Required master port class		A
Process data analog		6
Process data binary		8
Min. process cycle time	[ms]	1.9

SMF650



Magnetic-inductive flow meter

SMG80KGFFRKG/UST

IO-Link process data (cyclical)	Function	bit length
	totalizer	32
	flow	32
	temperature	32
	conductivity	32
	status	4
IO-Link functions (acyclical)	binary switching information	8
	direction of flow detection; totalizer; memory; operating hours counter; internal temperature; simulation function	
Supported DeviceIDs	Type of operation	DeviceID
	default	1800

Operating conditions		
Ambient temperature	-20...65 °C	-4...149 °F
Storage temperature	-20...80 °C	-4...176 °F
Protection	IP 67; IP 69; (to DIN EN 60529)	

Tests / approvals		
EMC	DIN 61326-1	
CPA approval	model number	SMF
	accuracy class	0,5
Shock resistance	DIN IEC 68-2-27	20 g (18ms)
Vibration resistance	DIN IEC 68-2-6	5 g (10...2000Hz)
MTTF [years]	82	
UL approval	UL approval number	I032
Pressure equipment directive	sound engineering practice; can be used for group 2 fluids; group 1 fluids on request	

Mechanical data		
Weight [g]	7657.8	
Housing	tubular	
Inlet pipe length	5 x DN	
Outlet pipe length	2 x DN	
Dimensions [mm]	Ø 168.3 / L = 140	
Material	housing: stainless steel (1.4404 / 316L); flange: stainless steel (1.4301 / 304); electronics fixture: stainless steel (1.4301 / 304); electronics: stainless steel (1.4404 / 316L); LED ring: PP	
Materials (wetted parts)	Pipe section: PFA; electrodes: stainless steel (1.4435 / 316L)	
Nominal diameter	DN80 (3")	
Process connection	ifm-specific device flange	
Surface characteristics Ra/Rz of the wetted parts	Ra < 0.4 µm	

Displays / operating elements		
Display	operating status	LED ring, three-color
Factory setting	m³/h; °C; µS/cm	

SMF650



Magnetic-inductive flow meter

SMG80KGFFRKG/UST

Remarks	
Remarks	MW = Measured value
	MEW = Final value of the measuring range
	pulse and totalizer signal are only available for one of the two outputs
	reference conditions (1/2): water (free of gas bubbles), 15...35 °C, process connection: DIN32676 series A, pipe standard suitable for process connection
	reference conditions (2/2): inlet pipe length 10xDN, outlet pipe length 5xDN, device settling time: 30 minutes, device orientation: horizontal, display orientation: up
Pack quantity	1 pcs.

Electrical connection

Connector: 1 x M12; coding: A; Contacts: gold-plated



Connection

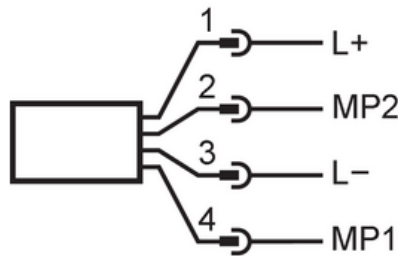

Electrical connection - plug

1	L+	
2	MP2	DO2, AO, Reset
3	L-	
4	MP1	DO1, IO-Link

AO: analog output; DO: digital output; MP: multi-function connection