

SDL100

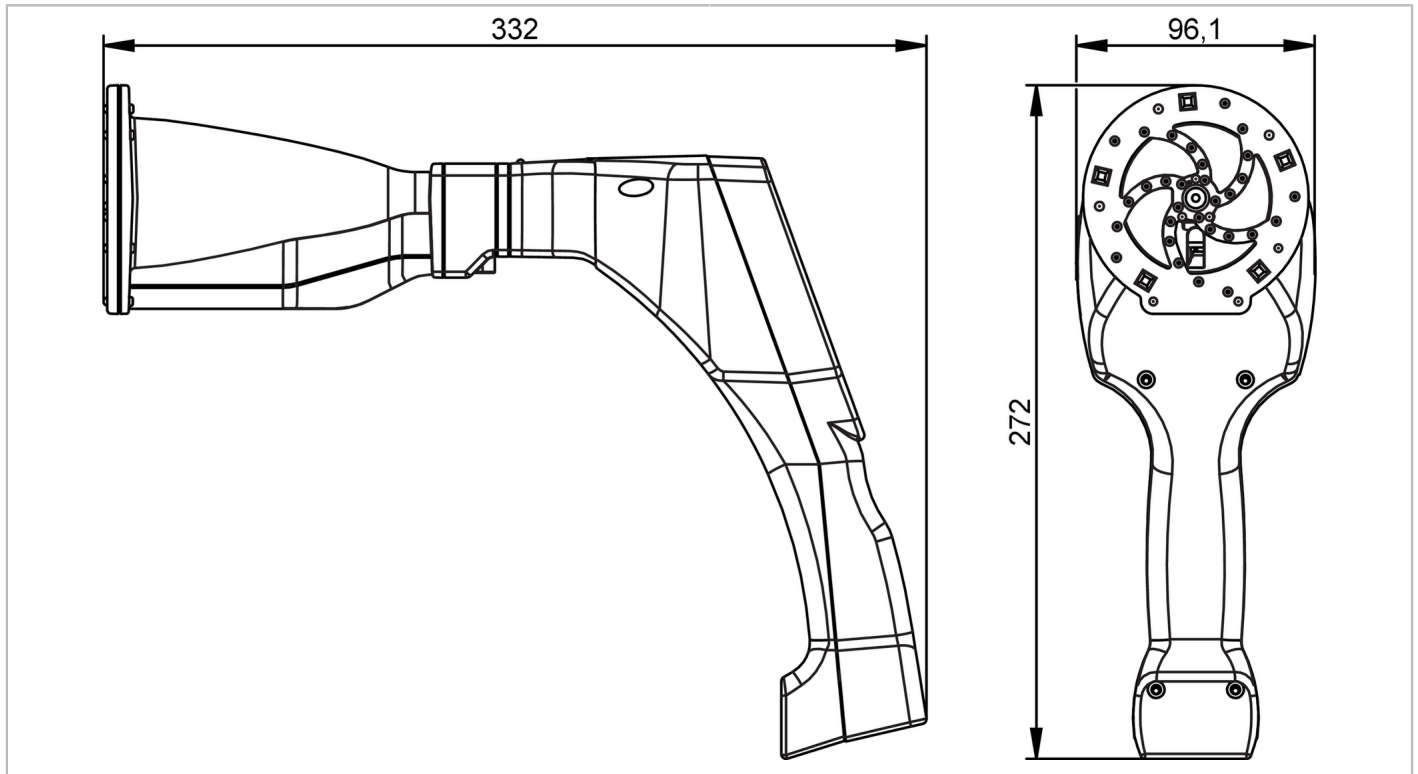

Hand-held device for the location of leaks

ULTRASOUND CAMERA



Application	
Application	[m] 1...6
Application	for industrial indoor applications
Media	compressed air; nitrogen (N2)
Electrical data	
Operating voltage	[V] 7.4 DC; (rechargeable lithium-ion battery; permanent operation: approx. 6 h ; maximum charging time 4 h)
Type of light	Infrared light
Monitoring range	
Wave length range	[nm] 645...660
Measuring/setting range	
Frequency range	[kHz] 40; (± 2)
Measuring principle	30 MEMS microphones
Measuring range	[l/min] > 0.1
Note on measuring range	5 m distance at 6 bar
Accuracy / deviations	
Accuracy	± 2 dB
Software / programming	
Parameter setting options	via PC using leak report software
Interfaces	
Communication interface	USB; WLAN

SDL100



Hand-held device for the location of leaks

ULTRASOUND CAMERA

Operating conditions	
Ambient temperature [°C]	-5...50
Storage temperature [°C]	-20...60
Max. relative air humidity [%]	95
Max. height above sea level [m]	4000
Protection	IP 20
Degree of soiling	2
Tests / approvals	
EMC	DIN EN IEC 61326-1 : 2022-11
	DIN EN 55011 : 2022-05
Laser protection class	2
Notes on laser protection	Caution - Laser light
	Power: <1 mW
	Wave length: 645...660 nm
	Do not stare into beam.
	Avoid exposure to the laser light. laser class: 2
Mechanical data	
Weight [g]	4527.4
Housing	rectangular
Type of mounting	portable hand-held device
Dimensions [mm]	272 x 96.1 x 332
Displays / operating elements	
Display	3.5" - TFT touch panel transmissive
Language	English; German; Spanish; Italian; Danish; Polish; French; Portuguese; Romanian; Czech
Operating elements	4 capacitive pushbuttons
Data memory	
Memory size	16 GB
Accessories	
Items supplied	external battery charger
	Leak Tag Block
	USB stick
	Leak report Software
	headphones, jack plug 3,5 mm
Remarks	
Remarks	brightness sensor activates LEDs in dark environments
	auto level: automatically adjusts the sensitivity to the environment and suppresses background noise
	function for estimating leakages (l/min or cfm) and the resulting costs per year
	integrated laser distance measurement
	the leakage can be heard from a greater distance; the user must approach the leakage to locate it accurately
Pack quantity	1 pcs.

SDL100



Hand-held device for the location of leaks

ULTRASOUND CAMERA

Electrical connection - USB interface

Connector: USB

