

# RUP500

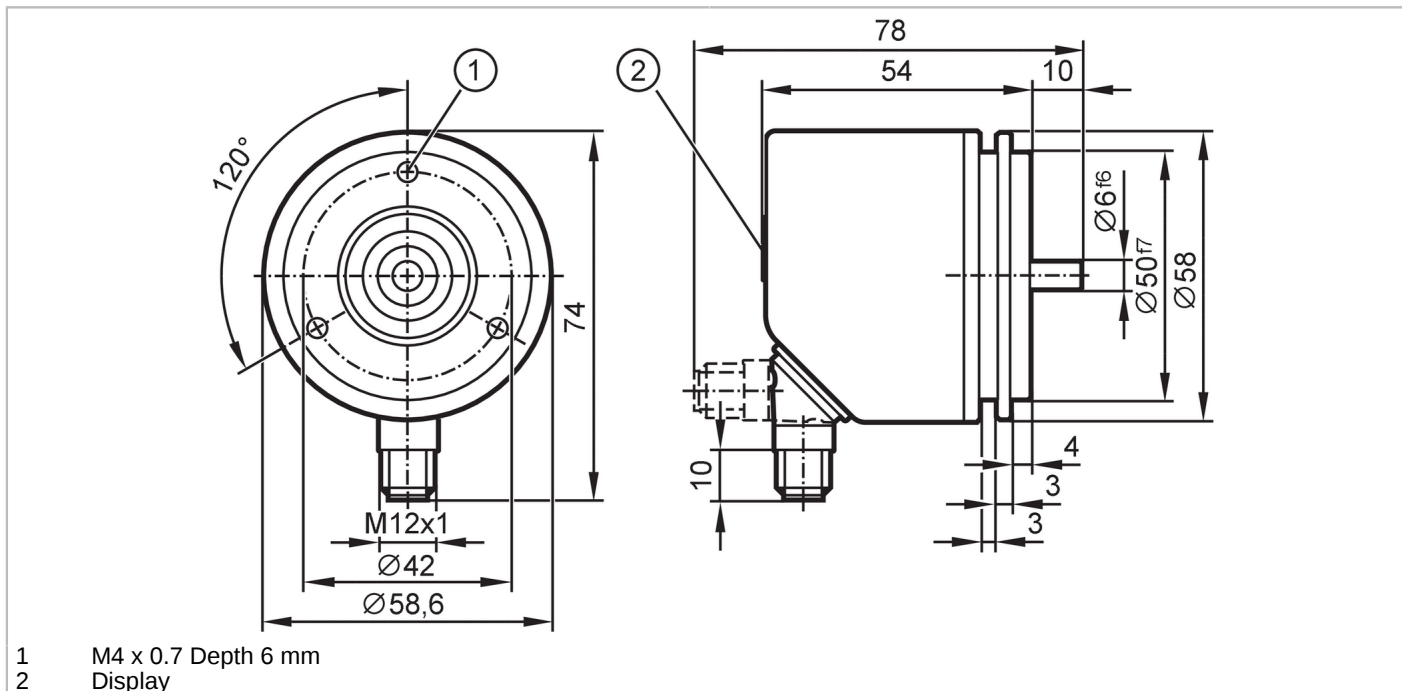

## Incremental encoder with solid shaft and display

INCREMENTAL ENCODER PERFORMANCE LINE



### Product characteristics

Resolution	1...10000; (configurable; Factory setting: 1024) resolution
Communication interface	IO-Link
Shaft design	solid shaft
Shaft diameter [mm]	6

### Application

Function principle	incremental
Detection system	magnetic
Application	encoder; Speed monitor; Counter

### Electrical data

Operating voltage [V]	4.75...30 DC
Current consumption [mA]	< 350
Protection class	III
Reverse polarity protection	yes
Max. revolution electrical [U/min]	12000

### Outputs

Electrical design	HTL/TTL
Switching frequency [kHz]	1000
Factory setting	Output function: HTL (50 mA)
Short-circuit protection	yes
Phase difference A und B [°]	90

### Measuring/setting range

Resolution	1...10000; (configurable; Factory setting: 1024) resolution
------------	-------------------------------------------------------------

# RUP500



## Incremental encoder with solid shaft and display

INCREMENTAL ENCODER PERFORMANCE LINE

<b>Speed monitor</b>		
Set point SP	-9994...9999 U/min	-166.6...166.7 Hz
Reset point rP	-9999...9994 U/min	-166.7...166.6 Hz
<b>Counter</b>		
Preset point	1...9999	
<b>Accuracy / deviations</b>		
Accuracy	[°]	0.1
<b>Software / programming</b>		
Parameter setting options	encoder; Resolution; Direction of rotation; HTL; TTL; Speed monitor; Resolution	
<b>Interfaces</b>		
Communication interface	IO-Link	
Transmission type	COM2 (38,4 kBaud)	
IO-Link revision	1.1	
Profiles	Smart Sensor - SSP 0	Generic Profiled Sensor
	Function	Device identification
	Function	Process data variable
	Function	Device diagnosis
SIO mode	yes	
Min. process cycle time	[ms]	2.7
Supported DeviceIDs	<b>Type of operation</b>	<b>DeviceID</b>
	default	496
<b>Operating conditions</b>		
Ambient temperature	[°C]	-40...85
Storage temperature	[°C]	-40...85
Max. relative air humidity	[%]	95; (Condensation not permissible)
Protection	IP 65; (on the housing: IP 67; on the shaft: IP 64)	
<b>Tests / approvals</b>		
Shock resistance	100 g	
Vibration resistance	20 g	
MTTF	[years]	218
<b>Mechanical data</b>		
Weight	[g]	437
Housing	tubular	
Dimensions	[mm]	Ø 58 / L = 64
Material	flange: aluminum; housing: stainless steel; display window: PEI	
Max. revolution, mechanical	[U/min]	12000
Max. starting torque	[Nm]	0.01
Reference temperature torque	[°C]	20
Shaft design	solid shaft	
Shaft diameter	[mm]	6
Shaft material	stainless steel	
Max. shaft load axial (at the shaft end)	[N]	40

# RUP500



## Incremental encoder with solid shaft and display

INCREMENTAL ENCODER PERFORMANCE LINE

Max. shaft load radial (at the shaft end) [N]	60
-----------------------------------------------	----

Fixing flange	Synchro-flange
---------------	----------------

### Displays / operating elements

Display	10-segment display, red/green 4-digit configurable
	2 x LED, yellow
	5 x LED, green

### Remarks

Pack quantity	1 pcs.
---------------	--------

### Electrical connection

Connector: 1 x M12, radial, can also be used axially; coding: A; Contacts: 8; Moulded body: stainless steel; Maximum cable length: 100 m; (IO-Link: max. 20 m)

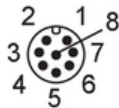

### IO-Link

1	L+
2	not to be used
3	L-
4	IO-Link
5	not to be used
6	not to be used
7	not to be used
8	not to be used
screen	plug

### encoder

1	UB
2	A
3	GND
4	Z/0-Pulse (90 deg)
5	B
6	A-
7	B-
8	Z-
screen	plug

### Speed monitor

1	UB
2	OUT2
3	GND
4	not to be used
5	OUT1
6	OUT2-
7	OUT1-
8	not to be used
screen	plug

# RUP500



## Incremental encoder with solid shaft and display

INCREMENTAL ENCODER PERFORMANCE LINE

### Preset counter

1	UB
2	IN1
3	GND
4	not to be used
5	OUT1
6	not to be used
7	not to be used
8	not to be used
screen	plug

### Diagrams and graphs

#### Pulse diagram

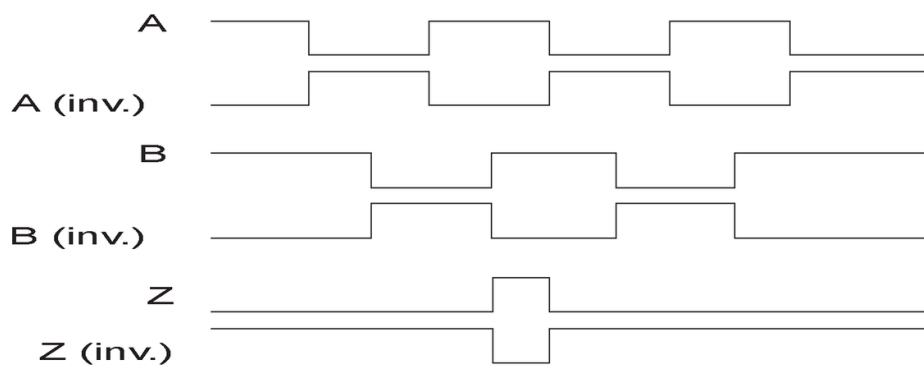

Direction of rotation clockwise (looking at the shaft)