

PI1708

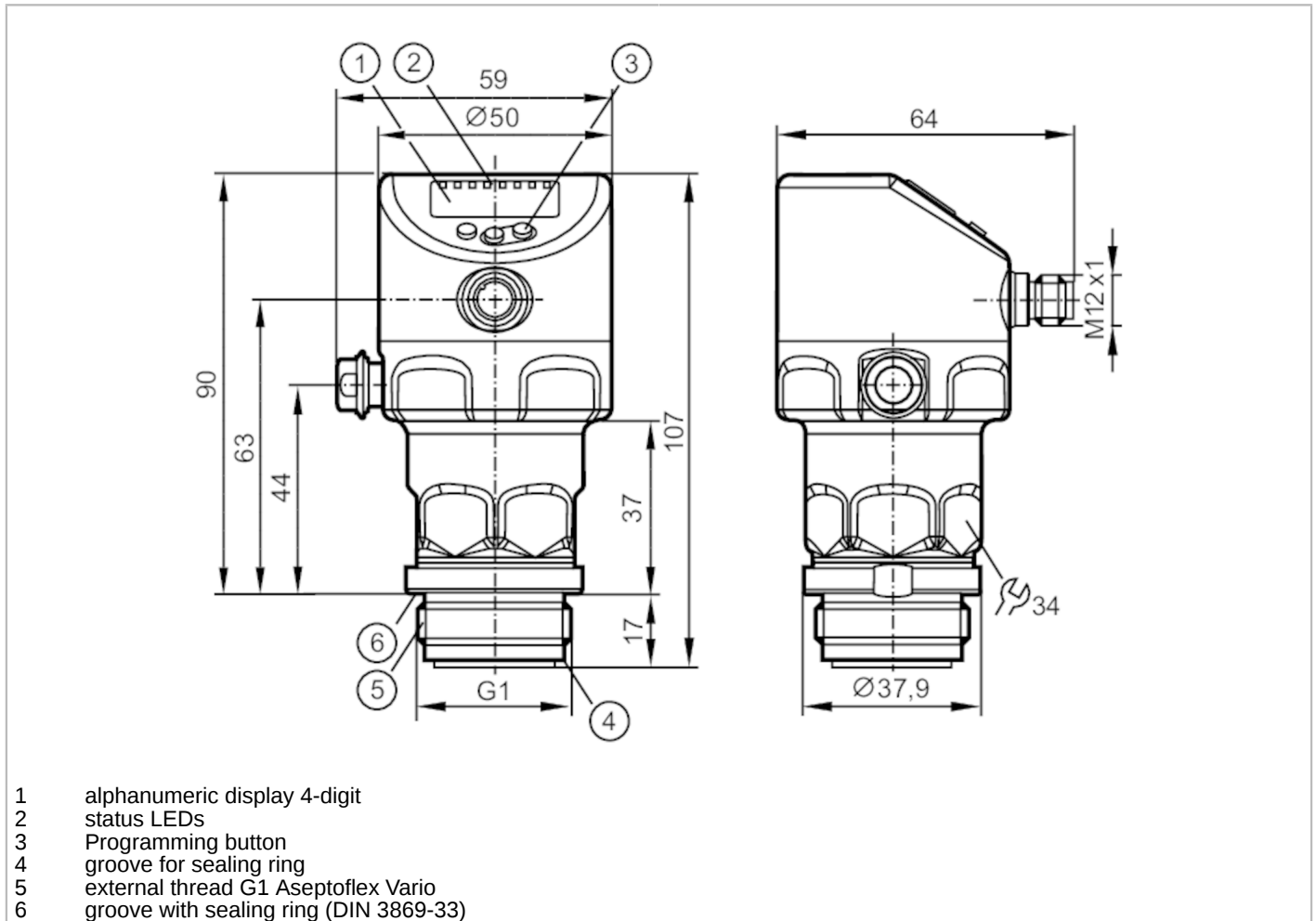

Flush pressure sensor with display

PI-,25BREA01-MFRKG/US/ IP



- 1 alphanumeric display 4-digit
- 2 status LEDs
- 3 Programming button
- 4 groove for sealing ring
- 5 external thread G1 Aseptoflex Vario
- 6 groove with sealing ring (DIN 3869-33)



ACS



CRN



EC 1935/2004

EHEDG Certified

FCM

FDA

IO-Link

NSF

Reg31

TSDP/TÜV

UK

CA

TSDP/TÜV UK CA

Product characteristics

Number of inputs and outputs	Number of digital outputs: 2; Number of analog outputs: 1			
Measuring range	-12.4...250 mbar	-5...100.4 inH2O	-1.24...25 kPa	-126...2550 mmWS
Process connection	threaded connection G 1 external thread Aseptoflex Vario			

Application

Special feature	gold-plated contacts		
Application	flush mountable for the food and beverage industry		
Media	viscous media and liquids with suspended particles; liquids and gases		
Medium temperature [°C]	-25...150		
Min. burst pressure	30000 mbar	12044 inH2O	3000 kPa
Pressure rating	6000 mbar	2400 inH2O	600 kPa
Vacuum resistance	-1000 mbar		-0.1 MPa
Type of pressure	relative pressure; vacuum		
No dead space	yes		
MAWP (for applications according to CRN) [bar]	6		

PI1708



Flush pressure sensor with display

PI-,25BREA01-MFRKG/US/ /P

Electrical data					
Min. insulation resistance	[MΩ]	100; (500 V DC)			
Protection class		III			
Reverse polarity protection		yes			
Integrated watchdog		yes			
2-wire					
Operating voltage	[V]	20...30 DC			
Current consumption	[mA]	3.5...21.5			
Power-on delay time	[s]	< 1			
3-wire					
Operating voltage	[V]	18...30 DC			
Current consumption	[mA]	5...45; (430 bei max. Laststrom)			
Power-on delay time	[s]	< 0.5			
Inputs / outputs					
Number of inputs and outputs		Number of digital outputs: 2; Number of analog outputs: 1			
Outputs					
Total number of outputs		2			
Output signal		switching signal; analog signal; IO-Link			
Electrical design		PNP/NPN			
Number of digital outputs		2			
Output function		normally open / closed; (configurable)			
Number of analog outputs		1			
Analog current output	[mA]	4...20, invertible; (scalable)			
Short-circuit protection		yes			
Type of short-circuit protection		yes (non-latching)			
Overload protection		yes			
2-wire					
Max. load	[Ω]	300			
3-wire					
Max. voltage drop switching output DC	[V]	2			
Permanent current rating of switching output DC	[mA]	100			
Switching frequency DC	[Hz]	125			
Max. load	[Ω]	(U _b - 10 V) / 21,5 mA; 650 Ω (U _b = 24 V)			
Measuring/setting range					
Measuring range		-12.4...250 mbar	-5...100.4 inH2O	-1.24...25 kPa	-126...2550 mmWS
Set point SP		-12...250 mbar	-4.8...100.4 inH2O	-1.2...25 kPa	-122...2549 mmWS
Reset point rP		-12.4...249.6 mbar	-5...100.2 inH2O	-1.24...24.96 kPa	-126...2545 mmWS
Analog start point		-12.4...199.4 mbar	-5...80.1 inH2O	-1.24...19.94 kPa	-126...2033 mmWS
Analog end point		38.2...250 mbar	15.3...100.4 inH2O	3.82...25 kPa	390...2549 mmWS
Min. difference between SP and rP		0.5 mbar	0.2 inH2O	0.05 kPa	5 mmWS
In steps of		0.1 mbar	0.1 inH2O	0.01 kPa	1 mmWS

PI1708



Flush pressure sensor with display

PI-,25BREA01-MFRKG/US/ /P

Factory setting	SP1 = 62.5 mbar	rP1 = 57.5 mbar
	SP2 = 187.5 mbar	rP2 = 182.5 mbar
	ASP = 0.00 mbar	AEP = 250 mbar
	dAP = 2.00 s	dAA = 2.00 s

Temperature monitoring		
Measuring range	-25...150 °C	-13...302 °F

Accuracy / deviations

Switch point accuracy [% of the span]	< ± 0,2; (DIN EN IEC 62828-1; Turn down 1:1)	
Repeatability [% of the span]	< ± 0,1; (with temperature fluctuations < 10 K; Turn down 1:1)	
Characteristics deviation [% of the span]	< ± 0,2; (DIN IEC EN 62828-1 incl. zero point and span error, non-linearity, hysteresis; Turn down 1:1)	
Linearity deviation [% of the span]	< ± 0,15; (Turn down 1:1)	
Hysteresis deviation [% of the span]	< ± 0,15; (Turn down 1:1)	
Long-term stability [% of the span]	< ± 0,1; (Turn down 1:1; per year)	
Total deviation over temperature range	Temperature range	total deviation
	-25...15 °C	Characteristics deviation ± 0,1 % of the span / 10 K
	15...80 °C	Characteristics deviation
	80...150 °C	Characteristics deviation ± 0,15 % of the span / 10 K
Notes on the accuracy / deviation	for further details see section Diagrams and graphs	

Temperature monitoring		
Accuracy [K]	± 2,5+ (0,08 x (Umgebungstemperatur - Mediumtemperatur))	
Repeatability [K]	± 0,2	
Resolution [K]	0.2	

Reaction times

Damping process value dAP [s]	0...99.99
Damping for the analog output dAA [s]	0...99.99

2-wire		
Step response time analog output [ms]	30	

3-wire		
Min. response time of switching output (dAP) [ms]	3	
Step response time analog output [ms]	7	

Temperature monitoring		
Dynamic response T05 / T09 [s]	< 45 / < 200; (DIN EN 60751 water ; > 0,9 m/s)	

Interfaces

Communication interface	IO-Link	
Transmission type	COM2 (38,4 kBaud)	

PI1708



Flush pressure sensor with display

PI-,25BREA01-MFRKG/US/ /P

IO-Link revision	1.1	
SDCI standard	IEC 61131-9	
Profiles	Common - I&D	Identification and Diagnosis
	Function	Measurement data, high resolution
SIO mode	yes	
Required master port class	A	
Min. process cycle time [ms]	5.6	
IO-Link resolution pressure [mbar]	0.01	
IO-Link resolution temperature [K]	0.2	
IO-Link process data (cyclical)	Function	bit length
	pressure	32
	temperature	32
	device status	4
	binary switching information	2
IO-Link functions (acyclical)	application specific tag; internal temperature; operating hours counter; switching cycles counter; Pressure peak counter	
Supported DeviceIDs	Type of operation	DeviceID
	default	1152

Operating conditions		
Ambient temperature [°C]	-25...80	
Storage temperature [°C]	-40...100	
Protection	IP 67; IP 68; IP 69K	

Tests / approvals		
EMC	DIN EN 61326-1	
Shock resistance	DIN EN 60068-2-27	50 g (11 ms)
Vibration resistance	DIN EN 60068-2-6	20 g (10...2000 Hz)
MTTF [years]	214	
Note on approval	Factory certificate available as download at www.factory-certificate.ifm	
UL approval	UL approval number	J048
	File number UL	E174189

Mechanical data		
Weight [g]	375.6	
Housing	tubular	
Dimensions [mm]	Ø 50 / L = 107	
Material	stainless steel (1.4404 / 316L); FKM; PTFE; PBT; PEI; PFA	
Materials (wetted parts)	ceramics (99.9 % Al2O3); stainless steel (1.4435 / 316L) surface characteristics: Ra < 0,4 µm / Rz = 4 µm; PTFE	
Min. pressure cycles	100 million	
Tightening torque [Nm]	35	
Process connection	threaded connection G 1 external thread Aseptoflex Vario	

Displays / operating elements		
Display	Display unit	LED, green
	Switching status	LED, yellow
	Function display	alphanumeric display, 4-digit
	Measured values	alphanumeric display, 4-digit

PI1708



Flush pressure sensor with display

PI-,25BREA01-MFRKG/US/ /P

Display unit | mbar; kPa; inH2O; mmWS

Remarks

Pack quantity | 1 pcs.

Electrical connection

Connector: 1 x M12; coding: A; Contacts: gold-plated



Connection

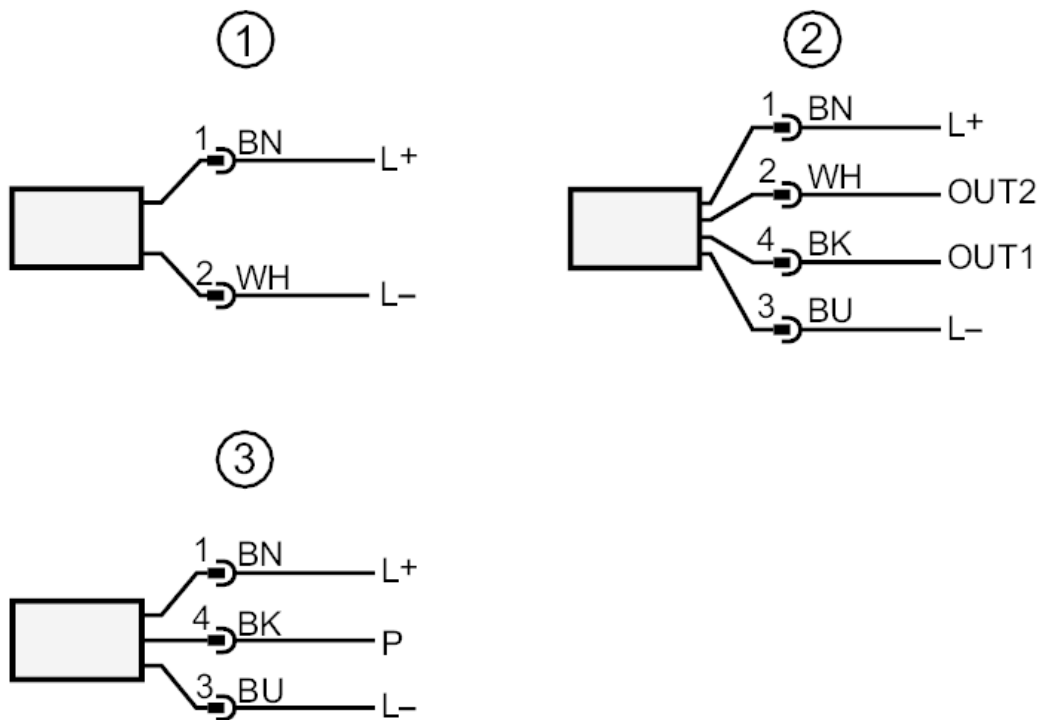

- 1 connection for 2-wire operation
- 2 connection for 3-wire operation
- OUT1 Switching output / IO-Link
- OUT2 Switching output / analog output
- 3 connection for IO-Link parameter setting (P = communication via IO-Link)

Colors to DIN EN 60947-5-2
Core colors

- BK = black
- BN = brown
- BU = blue
- WH = white

PI1708



Flush pressure sensor with display

PI-25BREA01-MFRKG/US/ /P

Diagrams and graphs

ambient temperature influence on the accuracy

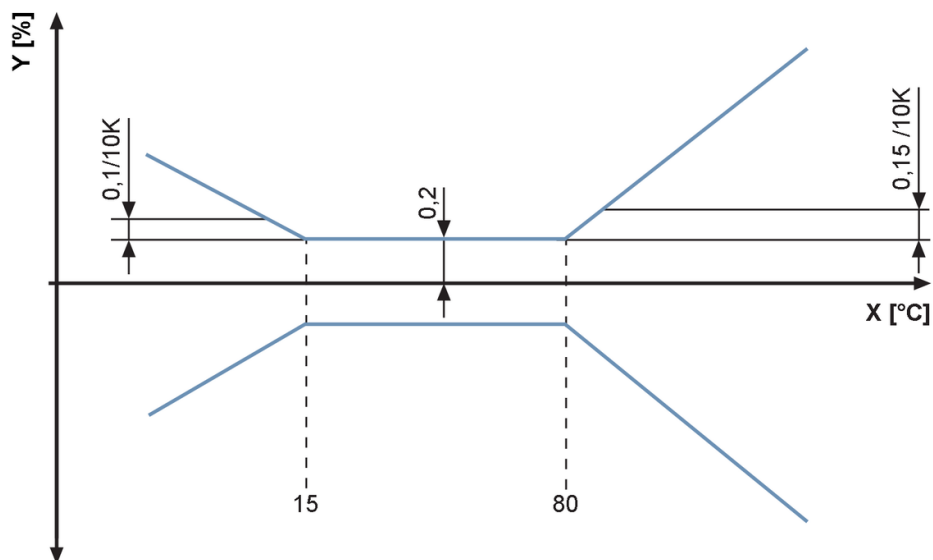

X temperature
Y total deviation