

OJ5058

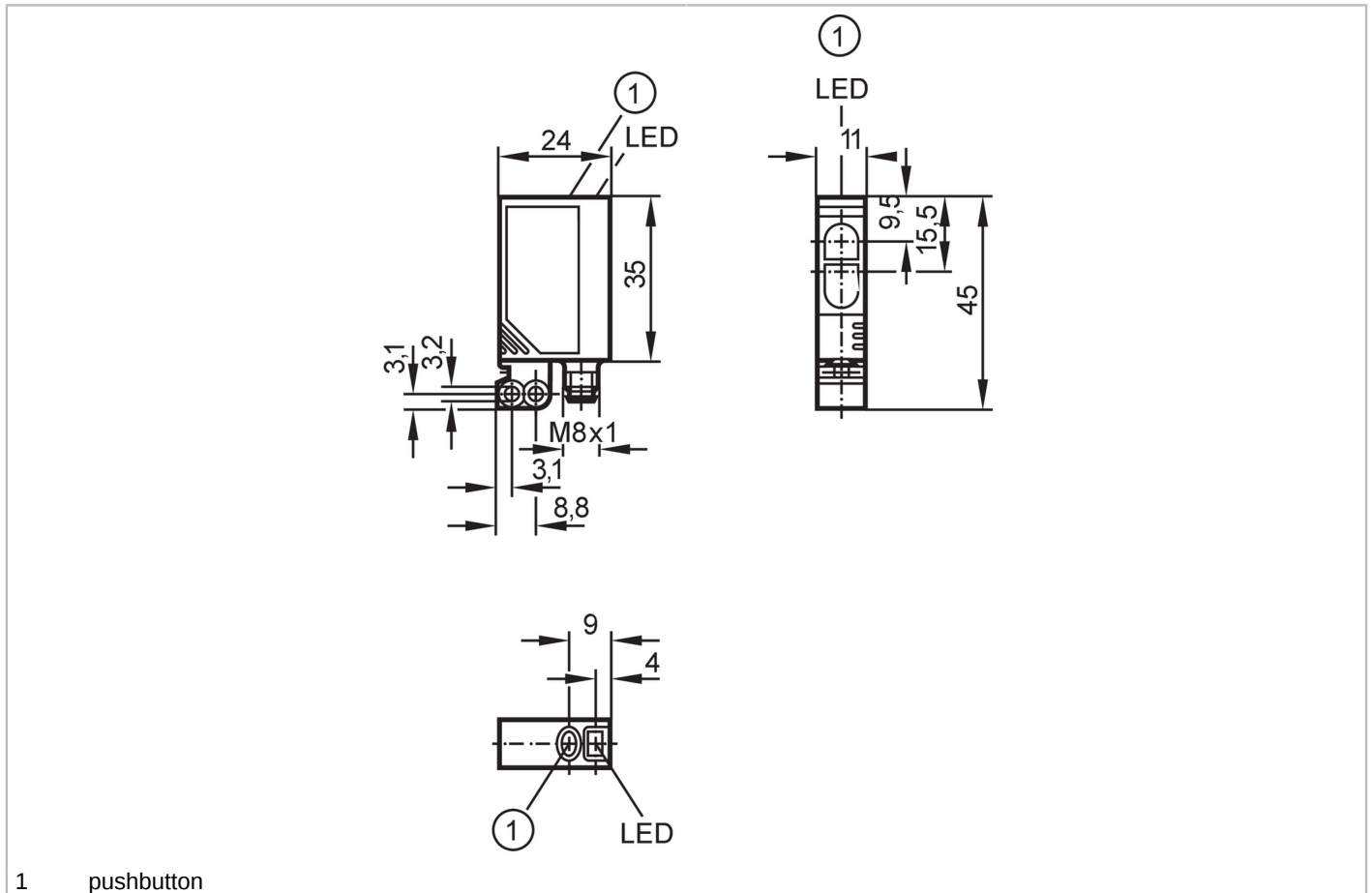

LASER diffuse reflection sensor

OJHLFPKG/SO/AS



Product characteristics	
Type of light	red light
Laser protection class	1
Housing	rectangular
Application	
Special feature	Background suppression
Function principle	Diffuse reflection sensor
Application	For applications in robotics, assembly and handling technology
Electrical data	
Operating voltage [V]	10...30 DC
Current consumption [mA]	13
Protection class	III
Reverse polarity protection	yes
Type of light	red light
Wave length [nm]	650
Typ. lifetime [h]	50000
Outputs	
Electrical design	PNP
Output function	light-on/dark-on mode; (programmable)

OJ5058



LASER diffuse reflection sensor

OJHLFPKG/SO/AS

Max. voltage drop switching output DC	[V]	2.5
Permanent current rating of switching output DC	[mA]	200
Switching frequency DC	[Hz]	1000
Short-circuit protection		yes
Type of short-circuit protection		yes (non-latching)
Overload protection		yes

Monitoring range

Range	[mm]	7...150; (white paper 200 x 200 mm 90 % remission)
Range on white object (90 % remission)	[mm]	7...150
Range on grey object (18 % remission)	[mm]	7...55
Range on black object (6 % remission)	[mm]	7...36
Range adjustable		yes
Diameter of the smallest detectable object	[mm]	0.8
Max. light spot diameter	[mm]	0.8
Background suppression available		yes

Operating conditions

Ambient temperature	[°C]	-10...60
Protection		IP 67

Tests / approvals

EMC	EN 60947-5-2	
Laser protection class	1	
Notes on laser protection	Caution:	Laser light
	laser class:	1
		EN / IEC60825-1:2007
		EN / IEC60825-1:2014
	Complies with 21 CFR 1040.10 except for conformance with IEC 60825-1 Ed. 3, as described in Laser Notice No. 56, dated May 8, 2019.	
MTTF	[years]	501

Mechanical data

Weight	[g]	27.75
Housing		rectangular
Dimensions	[mm]	35 x 11 x 24
Material		housing: ABS; fixture: diecast zinc; LED window: SEPS; pushbutton: SEPS
Lens material		front lens:PMMA
Lens alignment		Side sensing

Displays / operating elements

Display	Switching status	1 x LED, yellow
	Power	1 x LED, green

OJ5058



LASER diffuse reflection sensor

OJHLFPKG/SO/AS

Electronic lock yes

Accessories

Items supplied	Basic clip: 1, E20964
	screws: 2 x (M3 x 16 mm)
	spring washers: 2
	Nuts: 2

Remarks

Remarks	cULus - Class 2 source required
Pack quantity	1 pcs.

Electrical connection

Connector: 1 x M8; coding: A; Contacts: 4

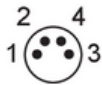

Connection

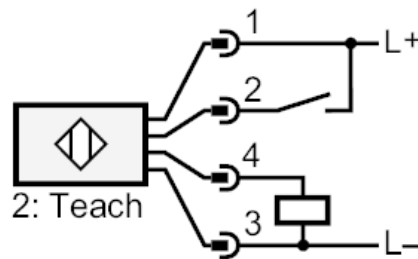

2 Teach

Diagrams and graphs

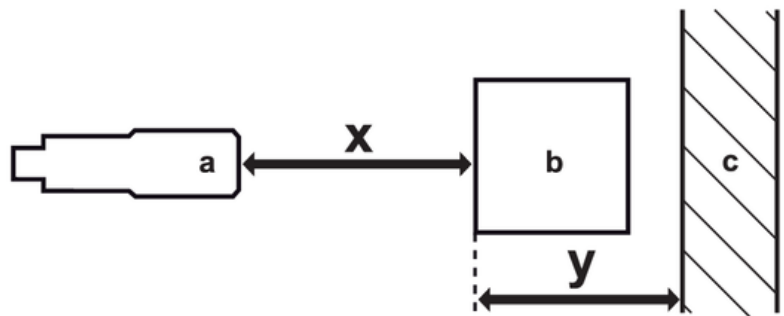

- a: sensor
- b: object
- c: background
- x: distance sensor/object [mm]
- y: min. distance object/background [mm]

OJ5058



LASER diffuse reflection sensor

OJHLFPKG/SO/AS

Background suppression chart

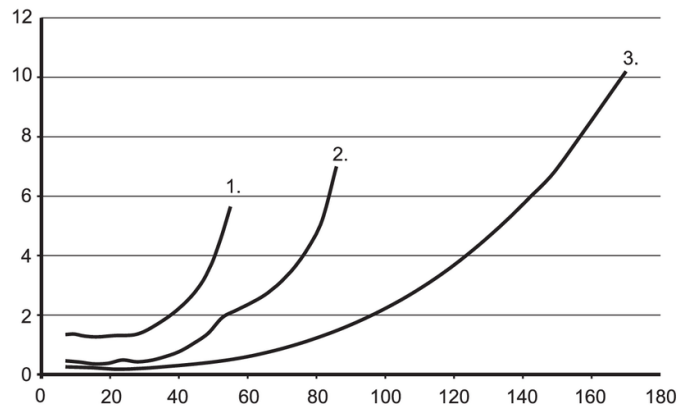

x: distance sensor/object [mm]

y: min. distance object/background [mm]

1 = object black (6 % remission) , Background white (90 % remission)

2 = object grey (18 % remission) , Background white (90 % remission)

3 = object white (90 % remission) , Background white (90 % remission)