

OG5126

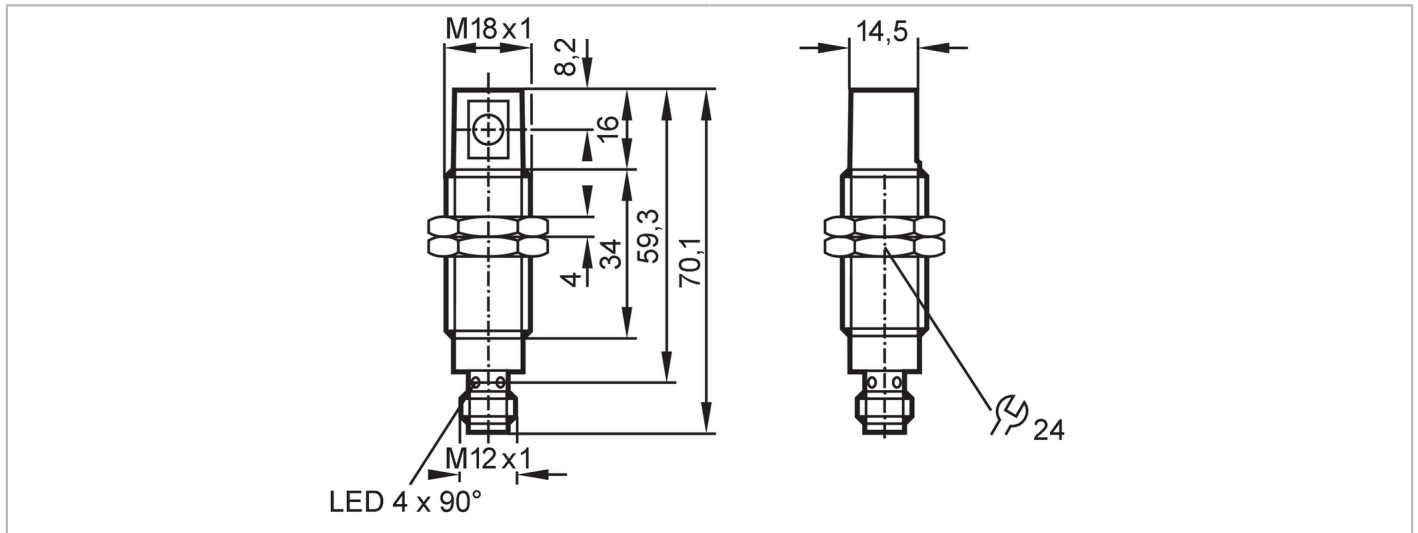

Retro-reflective sensor

OGP-DPKG/US/90°



Product characteristics	
Type of light	red light
Housing	Threaded type
Application	
Special feature	polarization filter
Function principle	Retro-reflective sensor
Application	Industrial applications
Electrical data	
Operating voltage [V]	10...30 DC; (cULus - Class 2 source required)
Current consumption [mA]	< 22
Protection class	II
Reverse polarity protection	yes
Type of light	red light
Wave length [nm]	660
Outputs	
Electrical design	PNP
Output function	dark-on mode
Max. voltage drop switching output DC [V]	2.5
Permanent current rating of switching output DC [mA]	200
Switching frequency DC [Hz]	500
Short-circuit protection	yes
Type of short-circuit protection	yes (non-latching)
Overload protection	yes
Monitoring range	
Range referred to prismatic reflector [m]	3; (Prismatic reflector Ø 80 E20005)

OG5126



Retro-reflective sensor

OGP-DPKG/US/90°

Range adjustable	no
Max. light spot diameter [mm]	96
Light spot dimensions refer to	at maximum range
Polarization filter available	yes

Operating conditions

Ambient temperature [°C]	-25...60
Protection	IP 68

Tests / approvals

EMC	EN 60947-5-2	
	EN 55011	class B
MTTF [years]	859	

Mechanical data

Weight [g]	59.2
Housing	Threaded type
Dimensions [mm]	M18 x 1 / L = 59.3
Thread designation	M18 x 1
Material	housing: stainless steel; cover: ABS
Lens material	front lens: PMMA

Displays / operating elements

Display	Switching status	1 x LED, yellow
	Power	1 x LED, green

Accessories

Items supplied	Nuts: 2 lock washers: 2
----------------	----------------------------

Remarks

Pack quantity	1 pcs.
---------------	--------

Electrical connection

Connector: 1 x M12; coding: A; Contacts: 4



Connection

