

OGT100

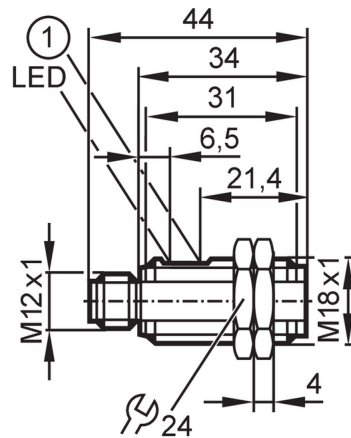

Diffuse reflection sensor

OGT-HPKG/US



- 1 potentiometer
Receiver in upper lens
transmitter in lower lens



Product characteristics

Type of light	red light
Housing	Threaded type

Application

Function principle	Diffuse reflection sensor
Application	For use in conveying and materials handling

Electrical data

Operating voltage	[V]	10...30 DC
Current consumption	[mA]	20
Protection class		III
Reverse polarity protection		yes
Type of light		red light
Wave length	[nm]	645

Outputs

Electrical design		PNP
Output function		light-on mode
Max. voltage drop switching output DC	[V]	2.5
Permanent current rating of switching output DC	[mA]	200
Switching frequency DC	[Hz]	1000
Short-circuit protection		yes
Overload protection		yes

Monitoring range

Range	[mm]	10...400; (white paper 200 x 200 mm 90 % remission)
Setting range	[mm]	70...400
Range adjustable		yes
Max. light spot diameter	[mm]	25
Light spot dimensions refer to		at maximum range

OGT100



Diffuse reflection sensor

OGT-HPKG/US

Operating conditions

Ambient temperature	[°C]	-25...60
Protection		IP 65; (in conjunction with a corresponding connector)

Tests / approvals

EMC		EN 60947-5-2
MTTF	[years]	641

Mechanical data

Weight	[g]	14.8
Housing		Threaded type
Dimensions	[mm]	M18 x 1 / L = 44
Thread designation		M18 x 1
Material		housing: ABS
Lens material		front lens:PMMA

Displays / operating elements

Display	Switching status	1 x LED, yellow
Operating elements		potentiometer

Accessories

Items supplied		lock nuts: 2
----------------	--	--------------

Remarks

Pack quantity		1 pcs.
---------------	--	--------

Electrical connection

Connector: 1 x M12; coding: A; Contacts: 4



Connection

