

O8T204

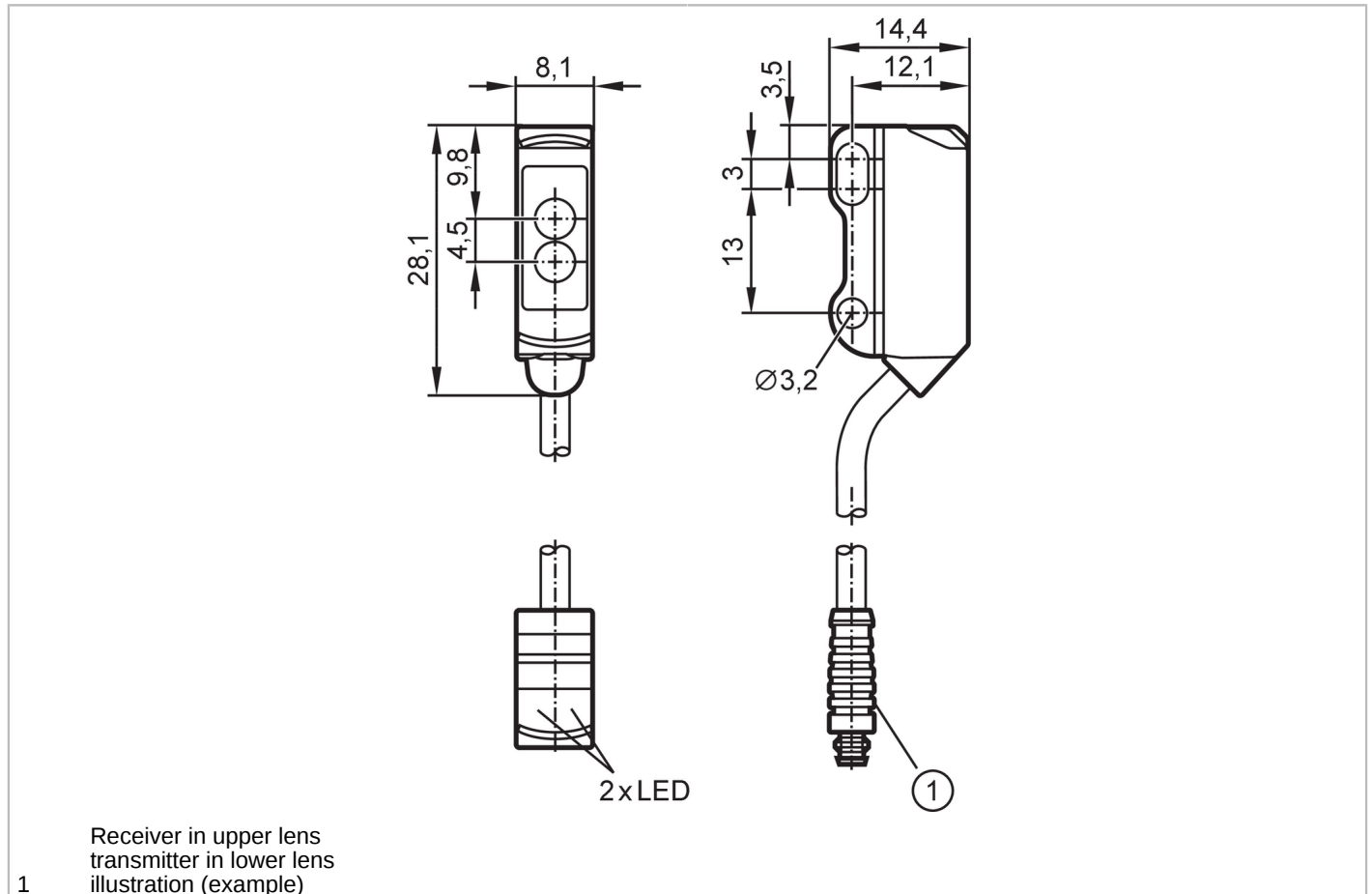

Diffuse reflection sensor

O8T-FPKG/IO-Link/0,30M/AS/4P



Product characteristics	
Type of light	red light
Housing	rectangular
Application	
Function principle	Diffuse reflection sensor
Electrical data	
Operating voltage [V]	10...30 DC
Current consumption [mA]	20; ((24 V))
Protection class	III
Reverse polarity protection	yes
Type of light	red light
Wave length [nm]	633
Outputs	
Electrical design	PNP
Output function	light-on/dark-on mode; (programmable)
Max. voltage drop switching output DC [V]	2.5
Permanent current rating of switching output DC [mA]	100

O8T204



Diffuse reflection sensor

O8T-FPKG/IO-Link/0,30M/AS/4P

Switching frequency DC [Hz]	1000
Short-circuit protection	yes
Type of short-circuit protection	yes (non-latching)

Monitoring range

Range [mm]	0...180; (white paper 200 x 200 mm)
Max. light spot diameter [mm]	18
Light spot dimensions refer to	at maximum range

Interfaces

Communication interface	IO-Link	
Transmission type	COM2 (38,4 kBaud)	
IO-Link revision	1.1	
SDCI standard	IEC 61131-9	
Profiles	Smart Sensor - SSP 0	Generic Profiled Sensor
	Function	Device identification
	Function	Multiple switching signal
	Function	Device diagnosis
	Function	Teach channel
SIO mode	yes	
Required master port class	A	
Min. process cycle time [ms]	2.5	
IO-Link process data (cyclical)	Function	bit length
	process value	8
	device status	4
	binary switching information	1
IO-Link functions (acyclical)	application specific tag; operating hours counter; switching cycles counter	
Supported DeviceIDs	Type of operation	DeviceID
	default	788

Operating conditions

Ambient temperature [°C]	-25...60
Protection	IP 65; IP 67

Tests / approvals

EMC	EN 60947-5-2	
MTTF [years]	1067	
UL approval	Ta	-25...60 °C
	Enclosure type	Type 1
	voltage supply	Limited Voltage/Current
	UL approval number	E017
	File number UL	E174191

Mechanical data

Weight [g]	21.1
Housing	rectangular
Dimensions [mm]	28.1 x 8.1 x 14.4
Material	housing: ABS; rear of the housing: stainless steel (1.4404 / 316L)
Lens material	front lens:PMMA
Lens alignment	Side sensing

O8T204



Diffuse reflection sensor

O8T-FPKG/IO-Link/0,30M/AS/4P

Displays / operating elements

Display	Switching status	1 x LED, yellow
	Power	1 x LED, green

Remarks

Pack quantity	1 pcs.
---------------	--------

Electrical connection

Cable: 0.3 m, PVC, black, Ø 2.9 mm; 3 x 0.08 mm²

Connector: 1 x M8; coding: A



Connection

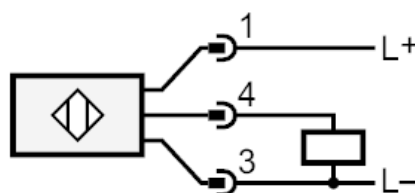

Diagrams and graphs

excess gain graph

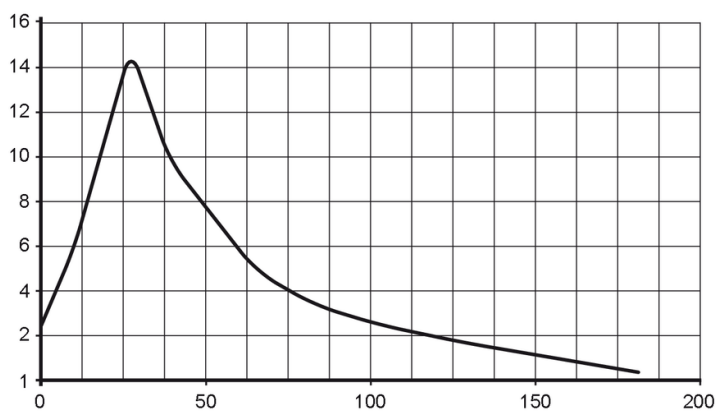

x: distance [mm]

y: excess gain factor