

O6S701

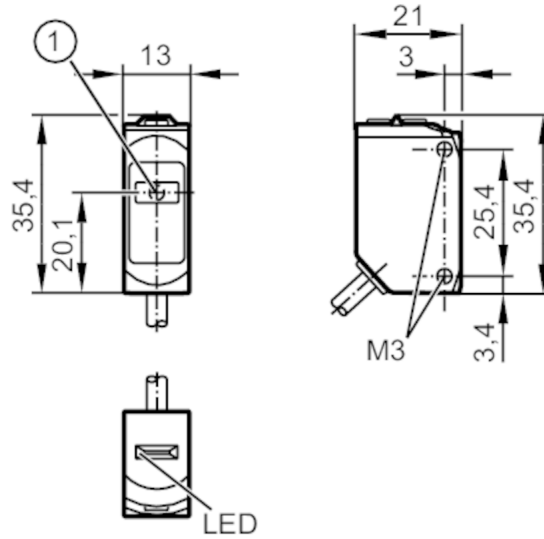

Through-beam sensor transmitter

O6SLOOKG/0,30m/US



1 Sensing surface



Product characteristics

Type of light	red light
Laser protection class	1
Housing	rectangular
Dimensions [mm]	35.4 x 13 x 21

Application

Function principle	Through-beam sensor
--------------------	---------------------

Electrical data

Operating voltage [V]	10...30 DC
Current consumption [mA]	10; (24 V)
Protection class	III
Reverse polarity protection	yes
Type of light	red light
Wave length [nm]	650

Monitoring range

Transmitter / receiver	transmitter
Range [m]	< 15
Diameter of the smallest detectable object [mm]	7; (15 m)
Max. light spot diameter [mm]	35
Light spot dimensions refer to	at maximum range

O6S701



Through-beam sensor transmitter

O6SLOOKG/0,30m/US

Interfaces		
Communication interface	IO-Link	
Transmission type	COM2 (38,4 kBaud)	
IO-Link revision	1.1	
SDCI standard	IEC 61131-9	
IO-Link device ID	523d / 00020Bh	
Profiles	Smart Sensor: Device Identification, Device Diagnosis	
SIO mode	no	
Required master port class	A	
Operating conditions		
Ambient temperature [°C]	-10...60	
Protection	IP 65; IP 67	
Tests / approvals		
EMC	EN 60947-5-2	
Laser protection class	1	
Notes on laser protection	Caution:	Laser light
	laser class:	1
		EN / IEC60825-1:2007
		EN / IEC60825-1:2014
		Complies with 21 CFR 1040 except for deviations pursuant to Laser Notice No. 50, dated June 2007.
MTTF [years]	697	
Mechanical data		
Weight [g]	33.2	
Housing	rectangular	
Dimensions [mm]	35.4 x 13 x 21	
Material	housing: ABS; PPSU; sealing: EPDM	
Lens material	PMMA	
Lens alignment	Side sensing	
Displays / operating elements		
Display	Power	1 x LED, green
Remarks		
Remarks	cULus - Class 2 source required	
Pack quantity	1 pcs.	
Electrical connection - plug		
Cable: 0.3 m, PUR, black, Ø 3.7 mm; 3 x 0.25 mm ²		
Connector: 1 x M12		

O6S701



Through-beam sensor transmitter

O6SLOOKG/0,30m/US

Connection

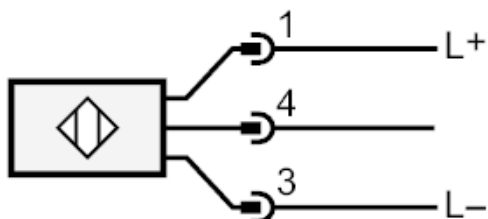

4 IO-Link

Diagrams and graphs

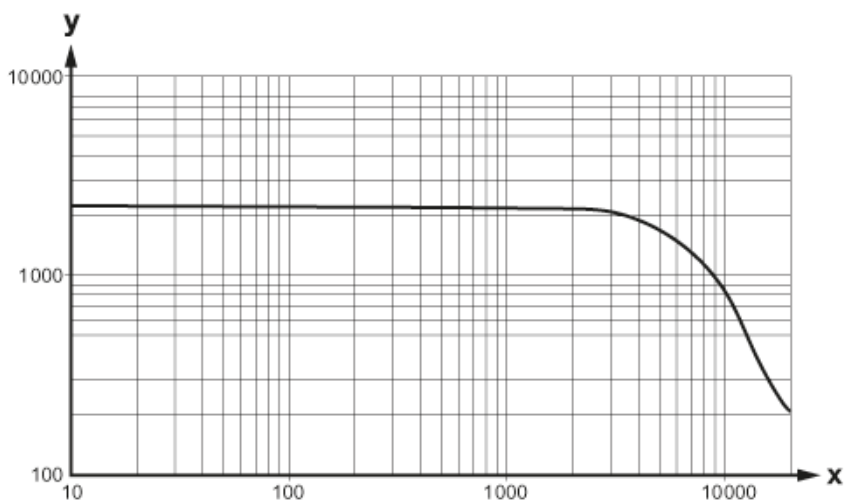

x: Abstand [mm]

y: Funktionsreservfaktor