

O5H504

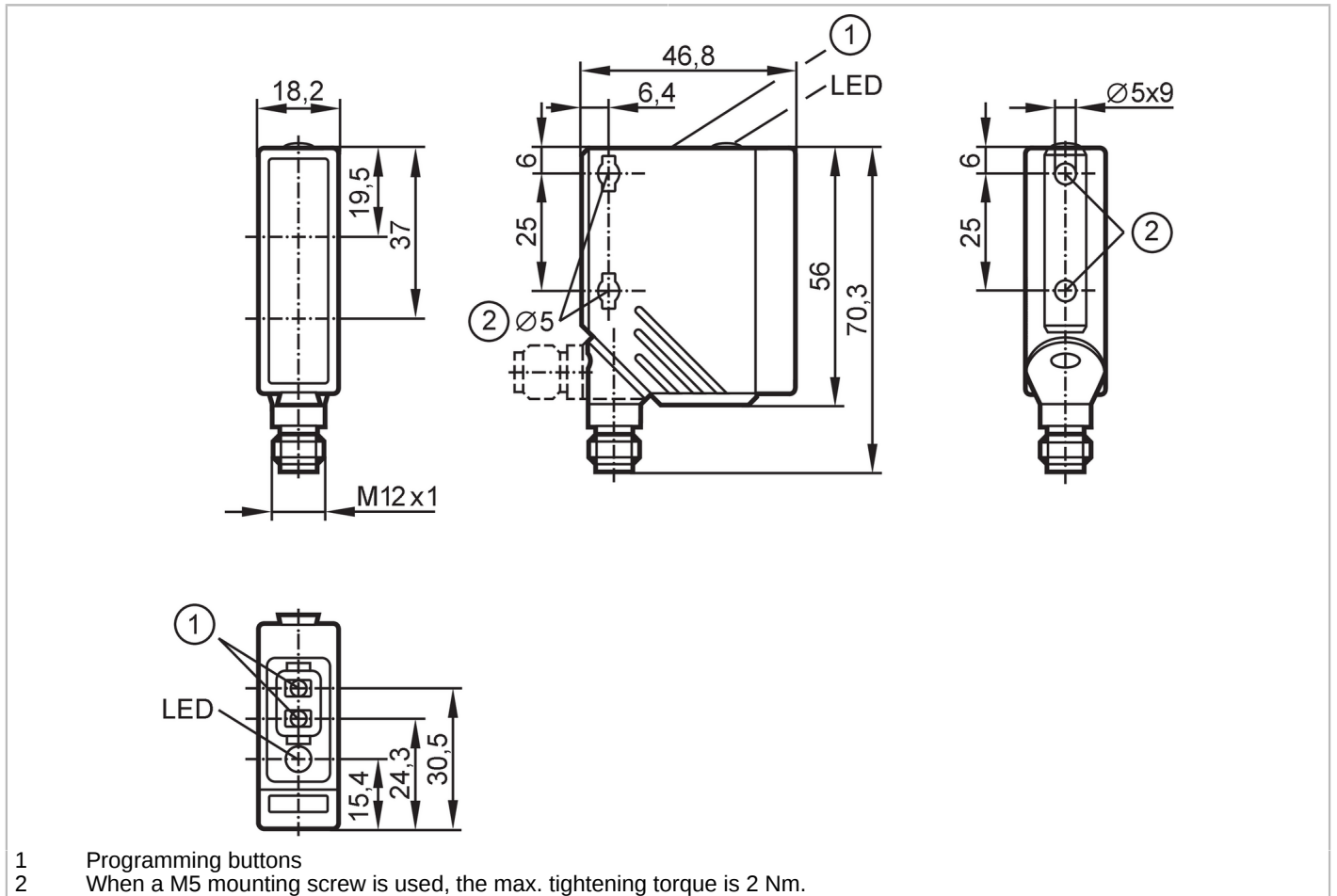

Diffuse reflection sensors with background suppression

O5H-FNKG/US100



Product characteristics	
Type of light	red light
Housing	rectangular
Application	
Special feature	Background suppression
Function principle	Diffuse reflection sensor
Application	Industrial applications
Electrical data	
Operating voltage [V]	10...36 DC
Current consumption [mA]	25
Protection class	II
Reverse polarity protection	yes
Type of light	red light
Wave length [nm]	624
Outputs	
Electrical design	NPN
Output function	light-on/dark-on mode; (programmable)

O5H504



Diffuse reflection sensors with background suppression

O5H-FNKG/US100

Max. voltage drop switching output DC	[V]	2.5
Permanent current rating of switching output DC	[mA]	200
Switching frequency DC	[Hz]	1000
Short-circuit protection		yes
Type of short-circuit protection		yes (non-latching)
Overload protection		yes

Monitoring range

Range	[mm]	50...1800; (white paper 200 x 200 mm 90 % remission)
Range on white object (90 % remission)	[mm]	50...1800
Range on grey object (18 % remission)	[mm]	50...900
Range on black object (6 % remission)	[mm]	50...600
Range adjustable		yes
Max. light spot diameter	[mm]	50
Light spot dimensions refer to		Range
Background suppression available		yes

Operating conditions

Ambient temperature	[°C]	-25...60
Protection		IP 67

Tests / approvals

EMC		EN 60947-5-2
MTTF	[years]	341

Mechanical data

Weight	[g]	67.5
Housing		rectangular
Dimensions	[mm]	56 x 18.2 x 46.8
Material		housing: PA; Front framework: stainless steel; operator interface: TPU (urethane)
Lens material		front lens:PMMA
Lens alignment		Side sensing

Displays / operating elements

Display	Switching status	1 x LED, yellow
Teach function		yes
Electronic lock		yes

Remarks

Remarks		cULus - Class 2 source required
Pack quantity		1 pcs.

Diffuse reflection sensors with background suppression

O5H-FNKG/US100

Electrical connection

Connector: 1 x M12; coding: A; Contacts: 4



Connection

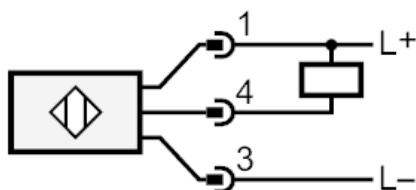

Diagrams and graphs

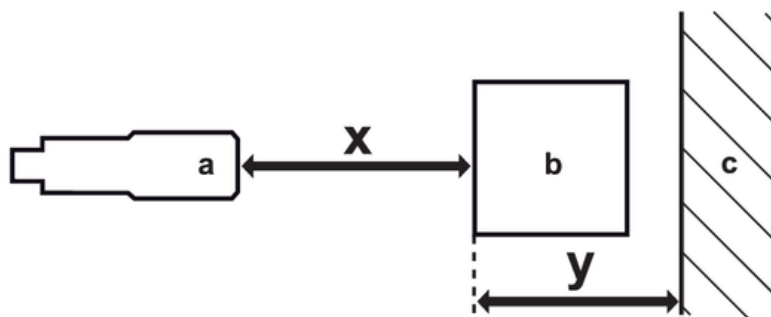

- a: sensor
- b: object
- c: background
- x: distance sensor/object [mm]
- y: min. distance object/background [mm]



Diffuse reflection sensors with background suppression

O5H-FNKG/US100

Background suppression chart

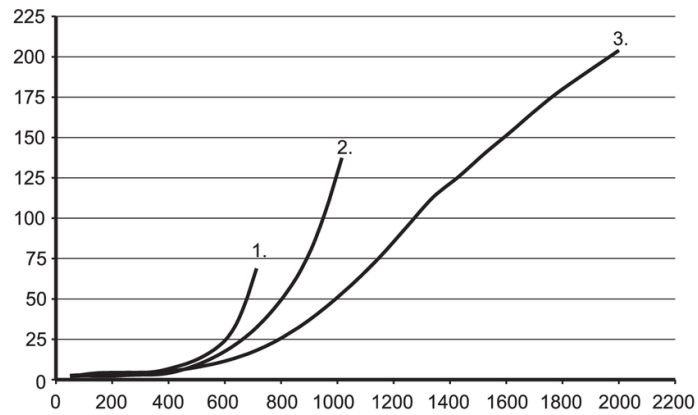

x: distance sensor/object [mm]

y: min. distance object/background [mm]

1 = object black (6 % remission) , Background white (90 % remission)

2 = object grey (18 % remission) , Background white (90 % remission)

3 = object white (90 % remission) , Background white (90 % remission)