

O1D103

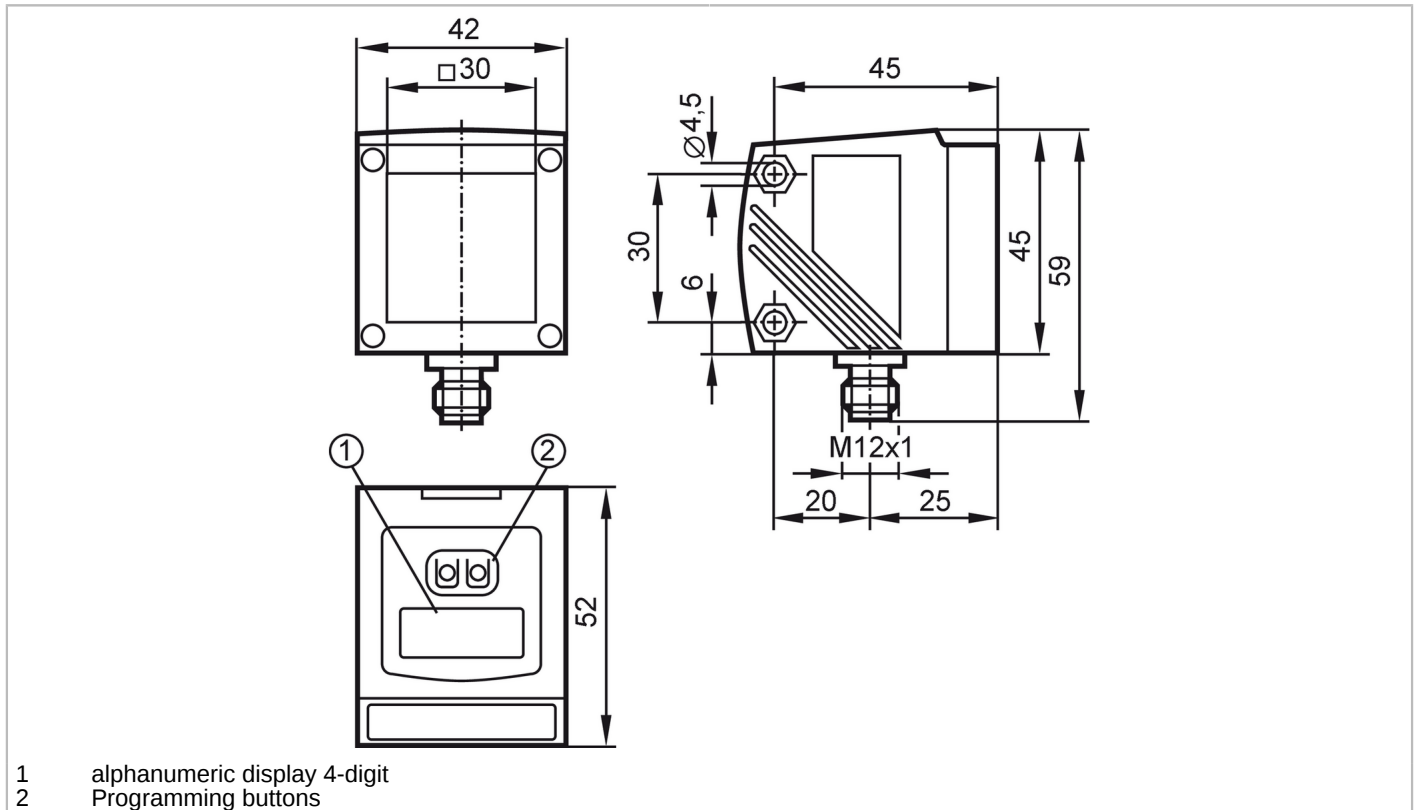

Laser distance sensor

O1DLF6KG/IO-LINK



Product characteristics	
Laser protection class	2
Housing	rectangular
Application	
Application	Industrial applications
Electrical data	
Operating voltage [V]	18...30 DC
Current consumption [mA]	< 150
Protection class	III
Reverse polarity protection	yes
Typ. lifetime [h]	50000
Inputs / outputs	
Number of inputs and outputs	Number of digital outputs: 2; Number of analog outputs: 1
Outputs	
Total number of outputs	2
Electrical design	NPN
Number of digital outputs	2
Output function	normally open / closed; (programmable)
Max. current load per output [mA]	200
Number of analog outputs	1
Analog current output [mA]	4...20; (IEC 61131-2)

O1D103



Laser distance sensor

O1DLF6KG/IO-LINK

Max. load	[Ω]	250
Analog voltage output	[V]	0...10; (IEC 61131-2)
Min. load resistance	[Ω]	5000
Short-circuit protection		yes
Type of short-circuit protection		yes (non-latching)
Overload protection		yes

Monitoring range

Max. light spot diameter	[mm]	25
Light spot dimensions refer to		10 m
Background suppression	[m]	10...19

Measuring/setting range

Measuring range	[m]	0.2...10; (white paper 200 x 200 mm 90 % remission)
Sampling rate	[Hz]	1...50

Interfaces

Communication interface	IO-Link	
Transmission type	COM2 (38,4 kBaud)	
IO-Link revision	1.1	
SDCI standard	IEC 61131-9	
Profiles	Smart Sensor - SSP 0	Generic Profiled Sensor
	Function	Device identification
	Function	Process data variable
	Function	Device diagnosis
	Function	Teach channel
SIO mode	yes	
Required master port class	A	
Process data analog	2	
Process data binary	2	
Min. process cycle time	[ms]	5
Supported DeviceIDs	Type of operation	DeviceID
	default	806

Operating conditions

Ambient temperature	[°C]	-10...60
Protection		IP 67

Tests / approvals

EMC	EN 60947-5-2	
Laser protection class	2	

O1D103



Laser distance sensor

O1DLF6KG/IO-LINK

Notes on laser protection	Caution:	Laser light
	Power:	<= 4 mW
	Wave length:	650 nm
	pulse:	1,3 ns
	Do not stare into beam.	
	Avoid exposure to the laser light.	
	laser class:	2
		EN / IEC60825-1:2007
		EN / IEC60825-1:2014
		Complies with 21 CFR 1040.10 except for conformance with IEC 60825-1 Ed. 3, as described in Laser Notice No. 56, dated May 8, 2019.
MTTF [years]	183	

Mechanical data

Weight [g]	313
Housing	rectangular
Dimensions [mm]	59 x 42 x 52
Material	housing: diecast zinc; front lens: glass; LED window: PC
Lens alignment	Side sensing

Displays / operating elements

Display	Switching status	2 x LED, yellow
	Power	LED, green
	Distance, programming	alphanumeric display, 4-digit

Accessories

Accessories (optional)	Protective cover, E21133
------------------------	--------------------------

Remarks

Remarks	cULus - Class 2 source required
Pack quantity	1 pcs.

Electrical connection

Connector: 1 x M12; coding: A; Contacts: 5

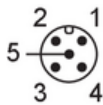

O1D103



Laser distance sensor

O1DLF6KG/IO-LINK

Connection

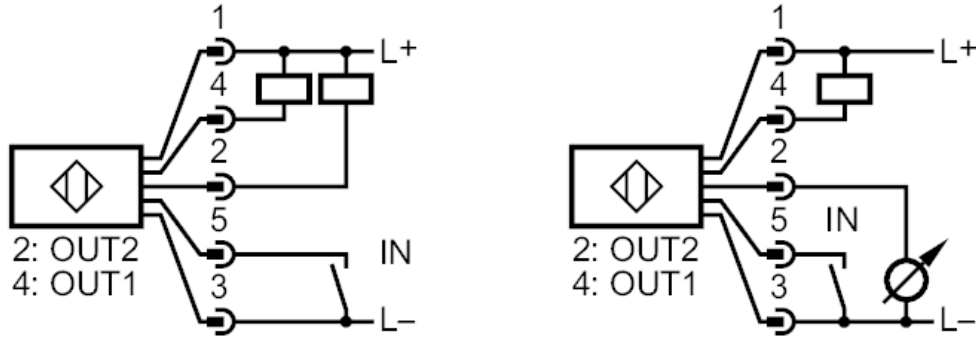

- 2: OUT2 Switching output or 4...20 mA / 0...10 V
- 4: OUT1 switching output or IO-Link
- 5: IN Laser On/ Off Ein / Aus

Other data

Parameter	Setting range	Factory setting
Uni	mm, m, inch	mm
OU1	Hno, Hnc, Fno, Fnc	Hno
SP1 [mm]	200...9999	1000
nSP1 [mm]	200...9999	800
FSP1 [mm]	200...9999	1200
OU2	Hno, Hnc, Fno, Fnc, I, U	I
SP2 [mm]	200...9999	2000
nSP2 [mm]	200...9999	1800
FSP2 [mm]	200...9999	2200
ASP [mm]	0...9999	0
AEP [mm]	0...9999	9999
rATE [Hz]	1...50	5
dS1 [s]	0...0.1...5	0
dr1 [s]	0...0.1...5	0
dS2 [s]	0...0.1...5	0
dr2 [s]	0...0.1...5	0
dFo [s]	0...0.1...5	0
dIS	d1...3 ; rd1...3; OFF	d3

O1D103



Laser distance sensor

O1DLF6KG/IO-LINK

Repeatability / Accuracy

distance	Repeatability of the measured values		Accuracy	
	white (90 % remission)	grey (18 % remission)	white (90 % remission)	grey (18 % remission)
200...1000 mm	± 5.0 mm	±7.5 mm	± 15.0 mm	± 18.0 mm
1000...2000 mm	± 5.5 mm	±10.0 mm	± 15.0 mm	± 20.0 mm
2000...4000 mm	± 17.5 mm	±22.5 mm	± 25.0 mm	± 32.0 mm
4000...6000 mm	± 27.5 mm	±40.0 mm	± 35.0 mm	± 50.0 mm
6000...10000 mm	± 60.0 mm		± 70.0mm	
Sampling rate	50 Hz			
Extraneous light on the object	< 40 klx			

Repeatability / Accuracy

distance	Repeatability of the measured values		Accuracy	
	white (90 % remission)	grey (18 % remission)	white (90 % remission)	grey (18 % remission)
200...1000 mm	± 16.5 mm	±16.5 mm	± 26.5 mm	± 26.5 mm
1000...2000 mm	± 16.5 mm	±16.5 mm	± 26.5 mm	± 26.5 mm
2000...4000 mm	± 30.0 mm	±37.0 mm	± 40.0 mm	± 47.0 mm
4000...6000 mm	± 37.0 mm	±57.0 mm	± 47.0 mm	± 67.0 mm
6000...10000 mm	± 75.0 mm	—	± 85.0mm	—
Sampling rate	50 Hz			
Extraneous light on the object	40...100 klx			

Repeatability / Accuracy

distance	Repeatability of the measured values		Accuracy	
	white (90 % remission)	grey (18 % remission)	white (90 % remission)	grey (18 % remission)
200...1000 mm	± 4.0 mm	±4.5 mm	± 14.0 mm	± 15.0 mm
1000...2000 mm	± 4.5 mm	±6.0 mm	± 14.5 mm	± 16.0 mm
2000...4000 mm	± 13.5 mm	±14.5 mm	± 23.5 mm	± 24.0 mm
4000...6000 mm	± 19.0 mm	±21.0 mm	± 29.0 mm	± 31.0 mm
6000...10000 mm	± 37.0 mm	—	± 47.0mm	—
Sampling rate	1 Hz			
Extraneous light on the object	< 40 klx			