

LMT100

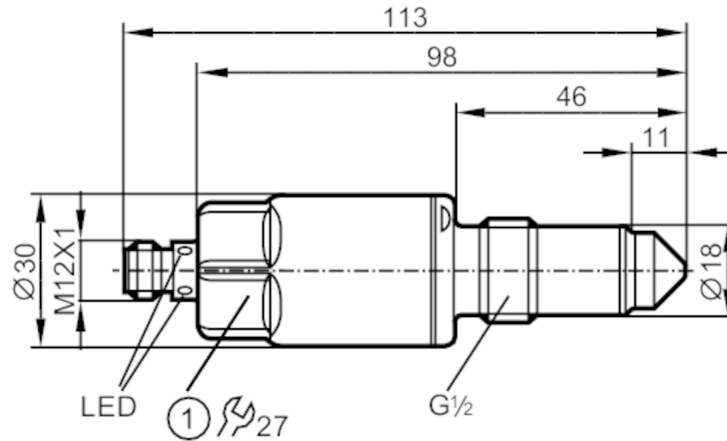

Sensor for point level detection

LMACE-A12E/QSKG/0/US



1 Tightening torque 20...25 Nm



ACS



CRN



UL LISTED



EAC

EC 1935/2004 EHEDG Certified



FCM



FDA



IO-Link



Reg31



Reg31



Reg31



Reg31



Reg31

Product characteristics

Number of inputs and outputs	Number of digital outputs: 2
Factory setting	water-based media
Process connection	threaded connection G 1/2 sealing cone

Application

System	gold-plated contacts
Media	Liquids; viscous media; powder
Cannot be used for	See the operating instructions, chapter "Function and features".
Probe length [mm]	11
Tank pressure [bar]	-1...40
MAWP (for applications according to CRN) [bar]	40

Oil	
Medium temperature [°C]	-40...100
Medium temperature short time [°C]	-40...150; (1 h)

Water	
Medium temperature [°C]	-40...100
Medium temperature short time [°C]	-40...150; (1 h)

Electrical data

Operating voltage [V]	18...30 DC
Current consumption [mA]	< 50
Protection class	III
Reverse polarity protection	yes

Inputs / outputs

Number of inputs and outputs	Number of digital outputs: 2
------------------------------	------------------------------

LMT100



Sensor for point level detection

LMACE-A12E/QSKG/0/US

Outputs		
Total number of outputs	2	
Output signal	switching signal; IO-Link	
Electrical design	PNP/NPN	
Number of digital outputs	2	
Output function	normally open / closed; (configurable)	
Max. voltage drop switching output DC [V]	2.5	
Permanent current rating of switching output DC [mA]	100	
Short-circuit protection	yes	
Type of short-circuit protection	yes (non-latching)	
Overload protection	yes	
Measuring/setting range		
Factory setting	water-based media	
Reaction times		
Response time [s]	< 0.5	
Interfaces		
Communication interface	IO-Link	
Transmission type	COM2 (38,4 kBaud)	
IO-Link revision	1.1	
SDCI standard	IEC 61131-9	
Profiles	Smart Sensor: Process Data Variable; Device Identification	
SIO mode	yes	
Required master port class	A	
Process data analog	1	
Process data binary	2	
Min. process cycle time [ms]	2.3	
Supported DeviceIDs	Type of operation	DeviceID
	default	304
Operating conditions		
Ambient temperature [°C]	-40...85	
Note on ambient temperature	Medium temperature: < 100 °C	
	-40...60 °C	
Storage temperature [°C]	Medium temperature: < 150 °C	
	-40...85	
Protection	IP 68; IP 69K	

LMT100



Sensor for point level detection

LMACE-A12E/QSKG/0/US

Tests / approvals		
EMC	DIN EN 61000-6-2	
	DIN EN 61000-6-4	: open tanks
	DIN EN 61000-6-3	: closed tanks
Shock resistance	DIN EN 60068-2-27	50 g (11 ms)
Vibration resistance	DIN EN 60068-2-6	20 g (10...2000 Hz)
MTTF [years]	223	
UL approval	UL approval number	H001

Mechanical data		
Weight [g]	208.5	
Material	stainless steel (1.4404 / 316L); PEEK; PEI; FKM	
Materials (wetted parts)	PEEK; surface characteristics: Ra < 0,8 / Rz 4	
Process connection	threaded connection G 1/2 sealing cone	

Displays / operating elements		
Display	Switching status	LED, yellow
	operating status	LED, green

Remarks		
Pack quantity	1 pcs.	

Electrical connection

Connector: 1 x M12; Contacts: gold-plated



LMT100



Sensor for point level detection

LMACE-A12E/QSKG/0/US

Connection

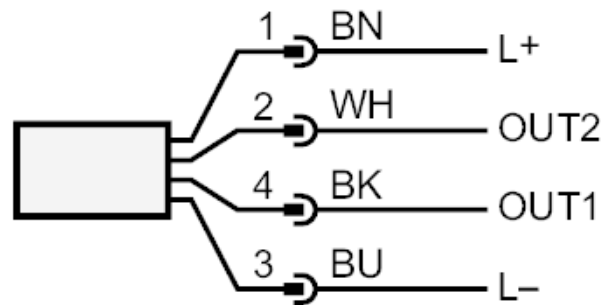

OUT1: Switching output IO-Link Teach

OUT2: Switching output

Colors to DIN EN 60947-5-2

Core colors :

BK = black

BN = brown

BU = blue

WH = white