



Inductive sensor

IIB3022-ANKG/US-104

Article to be discontinued
Discontinuation date: 03/31/2026

Alternative articles: IIS229
When selecting an alternative article and accessories please note that technical data may differ!

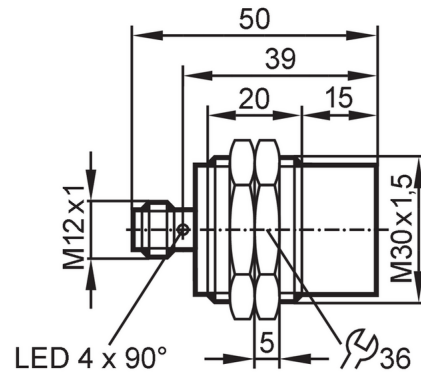

Product characteristics

Electrical design	NPN
Output function	normally open
Sensing range [mm]	22
Housing	Threaded type
Dimensions [mm]	M30 x 1.5 / L = 50

Application

Special feature	gold-plated contacts; Increased sensing range
Application	Suitable for industrial, mobile, cooling and lubricating applications; Industrial applications

Electrical data

Operating voltage [V]	10...30 DC
Current consumption [mA]	< 10
Protection class	III
Reverse polarity protection	yes

Outputs

Electrical design	NPN
Output function	normally open
Max. voltage drop switching output DC [V]	2.5
Permanent current rating of switching output DC [mA]	100
Switching frequency DC [Hz]	100
Short-circuit protection	yes
Overload protection	yes

Monitoring range

Sensing range [mm]	22
Real sensing range Sr [mm]	22 ± 10 %

IIS233



Inductive sensor

IIB3022-ANKG/US-104

Operating distance	[mm]	0...17.82
Increased sensing range		yes
Accuracy / deviations		
Correction factor		steel: 1 / stainless steel: 0.7 / brass: 0.5 / aluminum: 0.4 / copper: 0.3
Hysteresis	[% of Sr]	3...15
Switch-point drift	[% of Sr]	-10...10
Operating conditions		
Ambient temperature	[°C]	-40...85
Protection		IP 65; IP 66; IP 67; IP 68; IP 69K
Tests / approvals		
EMC	EN 61000-4-2 ESD	4 kV CD / 8 kV AD
	EN 61000-4-3 HF radiated	10 V/m
	EN 61000-4-4 Burst	2 kV
	EN 61000-4-6 HF conducted	10 V
	EN 55011	class B
Vibration resistance	EN 60068-2-6 Fc	20 g (10...3000 Hz) / 50 sweep cycles per frequency; 1 octave per minute in 3 axes
Shock resistance	EN 60068-2-27 Ea	100 g 11 ms half-sine; 3 shocks each in every direction of the 3 coordinate axes
Continuous shock resistance	EN 60068-2-27	40 g 6 ms; 4000 shocks each in every direction of the 3 coordinate axes
Fast temperature changes	EN 60068-2-14 Na	TA = -40 °C; TB = 85 °C; t1 = 30 min; t2 = < 10 s; 50 cycles
Salt spray test	EN 60068-2-52 Kb	severity level 5 (4 test cycles)
MTTF	[years]	1598
Embedded software included		yes
UL approval	Ta	-25...70 °C
	Enclosure type	Type 1
	voltage supply	Limited Voltage/Current
	UL approval number	A001
	File number UL	E174191
Mechanical data		
Weight	[g]	101.8
Housing		Threaded type
Mounting		non-flush mountable
Dimensions	[mm]	M30 x 1.5 / L = 50
Thread designation		M30 x 1.5
Material		housing: brass white bronze coated; LED window: PEI; lock nuts: brass white bronze coated; sensing face: PBT orange
Displays / operating elements		
Display	Switching status	4 x LED, yellow
Accessories		
Items supplied		lock nuts: 2
Remarks		
Pack quantity		1 pcs.

IIS233



Inductive sensor

IIB3022-ANKG/US-104

Electrical connection - plug

Connector: 1 x M12; coding: A; Contacts: gold-plated

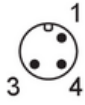

Connection

