

# IG5318

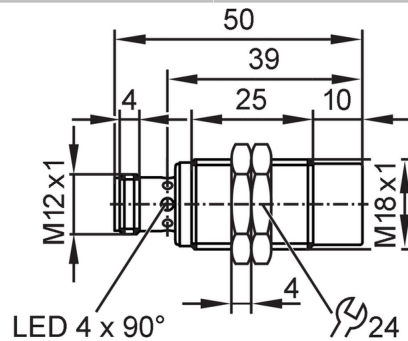

## Inductive sensor

IGB3008-BPKG/US-104



### Product characteristics

Electrical design	PNP
Output function	normally open
Sensing range [mm]	8
Housing	Threaded type
Dimensions [mm]	M18 x 1 / L = 50

### Application

Special feature	gold-plated contacts
-----------------	----------------------

### Electrical data

Operating voltage [V]	10...30 DC
Current consumption [mA]	< 10
Protection class	II
Reverse polarity protection	yes

### Outputs

Electrical design	PNP
Output function	normally open
Max. voltage drop switching output DC [V]	2.5
Permanent current rating of switching output DC [mA]	100
Switching frequency DC [Hz]	200
Short-circuit protection	yes
Overload protection	yes

### Monitoring range

Sensing range [mm]	8
Real sensing range Sr [mm]	8 ± 10 %
Operating distance [mm]	0...6.48

### Accuracy / deviations

Correction factor	steel: 1 / stainless steel: 0.7 / brass: 0.5 / aluminum: 0.4 / copper: 0.3
Hysteresis [% of Sr]	3...15
Switch-point drift [% of Sr]	-10...10

# IG5318



## Inductive sensor

IGB3008-BPKG/US-104

Operating conditions		
Ambient temperature	[°C]	-25...80
Protection		IP 67
Tests / approvals		
EMC	EN 60947-5-2	
	EN 55011	class B
MTTF	[years]	1134
Embedded software included		no
UL approval	Ta	0...40 °C
	Enclosure type	Type 1
	voltage supply	Limited Voltage/Current
	UL approval number	A001
	File number UL	E174191
Mechanical data		
Weight	[g]	41.6
Housing		Threaded type
Mounting		non-flush mountable
Dimensions	[mm]	M18 x 1 / L = 50
Thread designation		M18 x 1
Material		housing: brass white bronze coated; sensing face: PBT orange; LED window: PEI; lock nuts: brass white bronze coated
Displays / operating elements		
Display	Switching status	4 x LED, yellow
Accessories		
Items supplied		lock nuts: 2
Remarks		
Pack quantity		1 pcs.
Electrical connection - plug		
Connector: 1 x M12; coding: A; Contacts: 3, gold-plated		
		
Connection		
