

IG5595

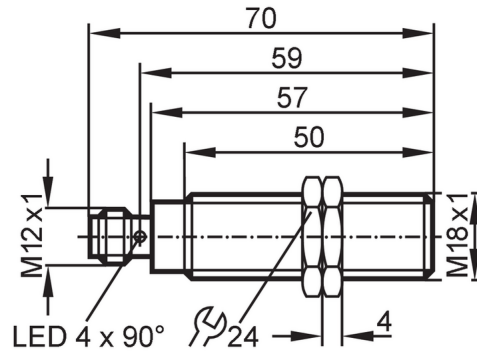

Inductive sensor

IGA2005-FRKG/US



Product characteristics

Electrical design	PNP/NPN
Output function	normally open / closed; (selectable)
Sensing range [mm]	5
Housing	Threaded type
Dimensions [mm]	M18 x 1 / L = 70

Application

Special feature	gold-plated contacts
-----------------	----------------------

Electrical data

Operating voltage [V]	10...55 DC
Current consumption [mA]	< 10
Protection class	II
Reverse polarity protection	yes

Outputs

Electrical design	PNP/NPN
Output function	normally open / closed; (selectable)
Max. voltage drop switching output DC [V]	2.5
Max. leakage current [mA]	0.5
Permanent current rating of switching output DC [mA]	400
Switching frequency DC [Hz]	700
Short-circuit protection	yes
Type of short-circuit protection	yes (non-latching)
Overload protection	yes

Monitoring range

Sensing range [mm]	5
Real sensing range S_r [mm]	$5 \pm 10\%$
Operating distance [mm]	0...4.05

Accuracy / deviations

Correction factor	steel: 1 / stainless steel: 0.7 / brass: 0.5 / aluminum: 0.4 / copper: 0.3
Hysteresis [% of S_r]	1...20

IG5595



Inductive sensor

IGA2005-FRKG/US

Switch-point drift	[% of Sr]	-10...10
Operating conditions		
Ambient temperature	[°C]	-25...70
Protection		IP 67
Tests / approvals		
EMC	EN 61000-4-2 ESD	4 kV CD / 8 kV AD
	EN 61000-4-3 HF radiated	10 V/m
	EN 61000-4-4 Burst	2 kV
	EN 61000-4-5 Surge	0,5 kV line to line, Ri: 2 Ohm
	EN 61000-4-6 HF conducted	10 V
	EN 55011	class B
MTTF	[years]	1775
UL approval	Ta	0...40 °C
	Enclosure type	Type 1
	voltage supply	Class 2
	File number UL	E174191
Mechanical data		
Weight	[g]	54.1
Housing		Threaded type
Mounting		flush mountable
Dimensions	[mm]	M18 x 1 / L = 70
Thread designation		M18 x 1
Material		housing: brass white bronze coated; sensing face: PBT
Displays / operating elements		
Display	Switching status	4 x 90° LED, yellow
Accessories		
Items supplied		lock nuts: 2
Remarks		
Pack quantity		1 pcs.

IG5595



Inductive sensor

IGA2005-FRKG/US

Electrical connection - plug

Connector: 1 x M12; coding: A; Contacts: 4, gold-plated

