

IFM204

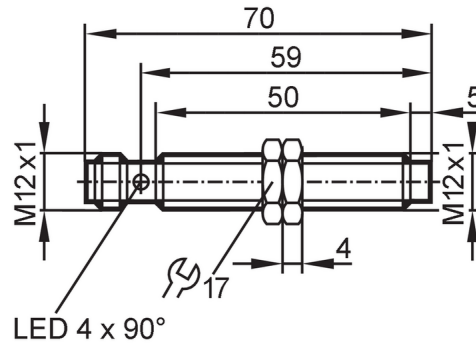

Inductive sensor

IFKC007-ASKG/V4A/US-104



Product characteristics

Electrical design		PNP/NPN
Output function		normally open
Sensing range	[mm]	7
Housing		Threaded type
Dimensions	[mm]	M12 x 1 / L = 70

Application

Special feature		gold-plated contacts; Increased sensing range
Application		Use in mobile and harsh applications

Electrical data

Operating voltage	[V]	10...36 DC
Current consumption	[mA]	< 10
Protection class		II
Reverse polarity protection		yes

Outputs

Electrical design		PNP/NPN
Output function		normally open
Max. voltage drop switching output DC	[V]	2.5
Minimum load current	[mA]	2; (only in 2-wire operation)
Max. leakage current	[mA]	0.5; (only in 2-wire operation)
Permanent current rating of switching output DC	[mA]	100
Switching frequency DC	[Hz]	300
Short-circuit protection		yes
Type of short-circuit protection		yes (non-latching)
Overload protection		yes

Monitoring range

Sensing range	[mm]	7
Real sensing range Sr	[mm]	7 ± 10 %
Operating distance	[mm]	0...5.67
Increased sensing range		yes

IFM204



Inductive sensor

IFKC007-ASKG/V4A/US-104

Accuracy / deviations		
Correction factor	steel: 1 / stainless steel: 0.7 / brass: 0.5 / aluminum: 0.4 / copper: 0.3	
Hysteresis [% of Sr]	1...20	
Switch-point drift [% of Sr]	-10...10	
Operating conditions		
Ambient temperature [°C]	-40...85	
Protection	IP 67; IP 69K	
Tests / approvals		
EMC	Automotive area	
	Noise emission and noise interference: ECE R10	E1 type approval
	noise immunity according to DIN ISO 11452-2	100 V/m
	conducted interference in 24 V networks to ISO 7637-2: 2004 (pulse 1 to 4) and ISO16750-2: 2012 (load dump)	
	pulse	1 2a 2b 3a 3b 4 Load dump
	Severity level	III III III III III III Test A
	Failure criterion	C A C A A C C
	EN 61000-4-2 ESD	4 kV CD / 8 kV AD
	EN 61000-4-3 HF radiated	10 V/m
	EN 61000-4-4 Burst	2 kV
	EN 61000-4-5 Surge	0,5 kV mains line to line
	EN 61000-4-6 HF conducted	10 V
	EN 55011	class B
	Fast temperature changes	EN 60068-2-14 Na
Salt spray test	EN 60068-2-52 Kb	severity level 5 (4 test cycles)
MTTF [years]	1253	
UL approval	Ta	0...40 °C
	Enclosure type	Type 1
	UL approval number	A051
	File number UL	E174191
Mechanical data		
Weight [g]	29.7	
Housing	Threaded type	
Mounting	non-flush mountable	
Dimensions [mm]	M12 x 1 / L = 70	
Thread designation	M12 x 1	
Material	housing: stainless steel (1.4404 / 316L); sensing face: LCP white; LED window: PEI; lock nuts: brass white bronze coated	
Tightening torque [Nm]	15	
Displays / operating elements		
Display	Switching status	4 x 90° LED, yellow
Accessories		
Items supplied	lock nuts: 2	
Remarks		
Pack quantity	1 pcs.	

IFM204



Inductive sensor

IFKC007-ASKG/V4A/US-104

Electrical connection - plug

Connector: 1 x M12; coding: A; Contacts: gold-plated



Connection

