

# I7R208

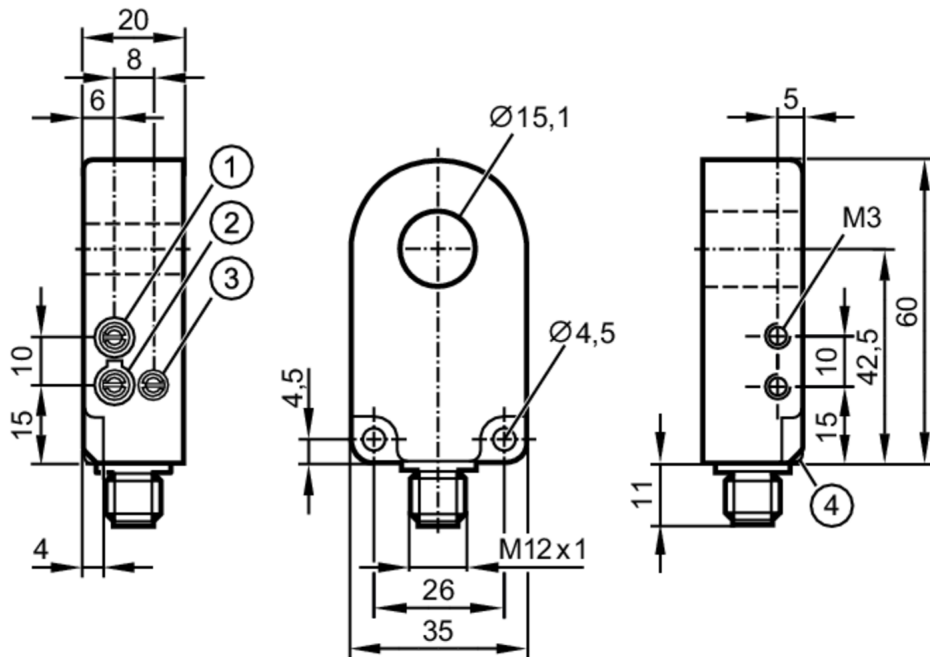

## Inductive ring sensor

I7R3015-FNKG/DY/US-100-INF



- 1 Sensitivity
- 2 Output function
- 3 Pulse stretching time



### Product characteristics

Electrical design	NPN
Output function	normally open / closed; (selectable)
Housing	circular
Dimensions [mm]	60 x 35 x 20

### Application

Principle of operation	dynamic
------------------------	---------

### Electrical data

Operating voltage [V]	10...35 DC
Current consumption [mA]	< 20
Protection class	III
Reverse polarity protection	yes

### Outputs

Electrical design	NPN
Output function	normally open / closed; (selectable)
Max. voltage drop switching output DC [V]	2
Permanent current rating of switching output DC [mA]	200
Short-circuit protection	yes
Overload protection	yes

# I7R208



## Inductive ring sensor

I7R3015-FNKG/DY/US-100-INF

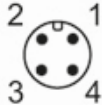
Monitoring range		
Resolution of steel ball (diameter)	[mm]	0.8
Max. part speed	[m/s]	35
Reaction times		
Pulse stretching	[ms]	0.1...150
Pulse stretching adjustable		yes
Max. fall time	[ms]	0.2
Response time	[ms]	< 0.2
Operating conditions		
Ambient temperature	[°C]	-25...70
Protection		IP 67
Tests / approvals		
MTTF	[years]	553
UL approval	Ta	-25...70 °C
	Enclosure type	Type 4X (indoor use only) / 12 and 13
	voltage supply	Class 2
	File number UL	E174191
Mechanical data		
Weight	[g]	58.5
Housing		circular
Dimensions	[mm]	60 x 35 x 20
Inside diameter	[mm]	15.1
Material		housing: PA; ring: POM
Displays / operating elements		
Display	Switching status	1 x LED, yellow
Remarks		
Pack quantity		1 pcs.
Electrical connection - plug		
Connector: 1 x M12; coding: A		
		

# I7R208



## Inductive ring sensor

I7R3015-FNKG/DY/US-100-INF

### Connection

