

# I7R205

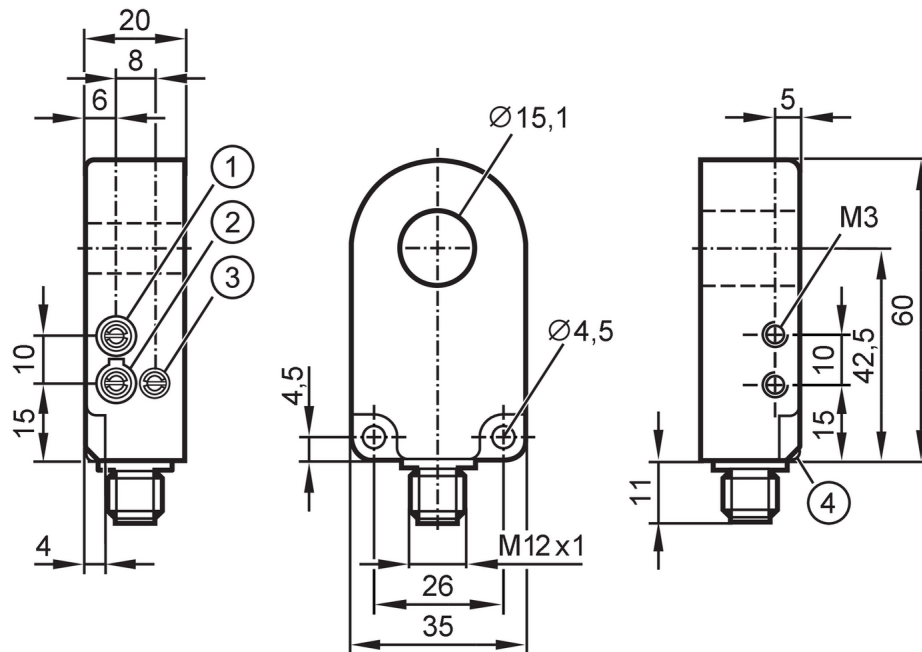

## Inductive ring sensor

I7R3015-FPKG/US-100-IPF



- 1 Sensitivity
- 2 Output function
- 3 Pulse stretching time



### Product characteristics

Electrical design	PNP
Output function	normally open / closed; (selectable)
Housing	circular
Dimensions [mm]	60 x 35 x 20

### Application

Principle of operation	static
------------------------	--------

### Electrical data

Operating voltage [V]	10...35 DC
Current consumption [mA]	< 11
Protection class	III
Reverse polarity protection	yes

### Outputs

Electrical design	PNP
Output function	normally open / closed; (selectable)
Max. voltage drop switching output DC [V]	2
Permanent current rating of switching output DC [mA]	200
Short-circuit protection	yes
Overload protection	yes

### Monitoring range

Resolution of steel ball (diameter) [mm]	2
--	---

# I7R205



## Inductive ring sensor

I7R3015-FPKG/US-100-IPF

Max. part speed	[m/s]	35
-----------------	-------	----

### Reaction times

Pulse stretching	[ms]	10...150
Pulse stretching adjustable		yes
Max. fall time	[ms]	10
Response time	[ms]	< 0.5

### Operating conditions

Ambient temperature	[°C]	-25...70
Protection		IP 67

### Tests / approvals

MTTF	[years]	658
UL approval	Ta	-25...70 °C
	Enclosure type	Type 4X (indoor use only) / 12 and 13
	voltage supply	Class 2
	File number UL	E174191

### Mechanical data

Weight	[g]	60.5
Housing		circular
Dimensions	[mm]	60 x 35 x 20
Inside diameter	[mm]	15.1
Material		housing: PA; ring: POM

### Displays / operating elements

Display	Switching status	1 x LED, yellow
---------	------------------	-----------------

### Remarks

Pack quantity	1 pcs.
---------------	--------

### Electrical connection - plug

Connector: 1 x M12; coding: A; Contacts: 4



### Connection

