

E43309

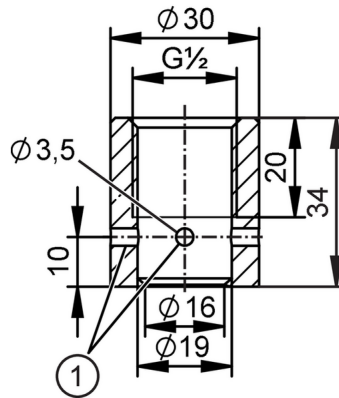

Welding adapter for process sensors

ADAPT G1/2-WELD SLEEVE 3A



1 Leakage port



CRN EC 1935/2004 EHEDG Certified FCM FDA

Application	
Design	for tanks, with leakage port (3A)
Pressure rating	50 bar 5 MPa
Note on pressure rating	for the connection sensor - adapter
MAWP (for applications according to CRN) [bar]	50
Tests / approvals	
Pressure equipment directive	A possible classification to PED depends on the application and has to be carried out by the user / operator.
Safety instructions	The compatibility between medium and product material has to be checked in all applications.
Mechanical data	
Weight [g]	166
Materials (wetted parts)	stainless steel (1.4435 / 316L)
Sensor connection	G 1/2 sealing cone
Process connection	Welding adapter Ø 30 mm
Surface characteristics Ra/Rz of the wetted parts	Ra < 0.4 µm / Rz = 4 µm
Remarks	
Pack quantity	1 pcs.