

E43108

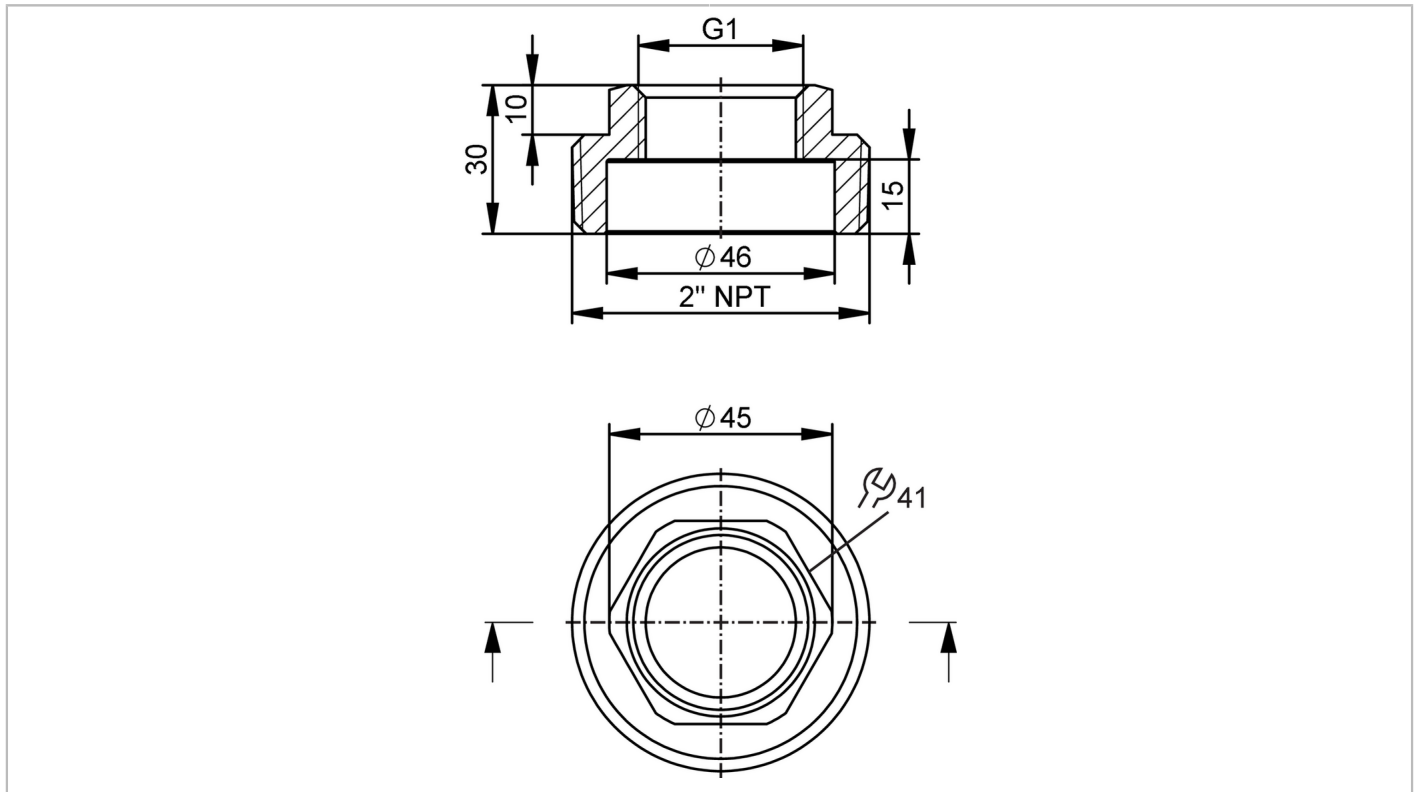

Screw-in adapter for process sensors

ADAPT G1 - 2 NPT



CRN

Application	
Design	for sensor LW2120
Pressure rating	50 bar 5 MPa
Note on pressure rating	for the connection sensor - adapter
MAWP (for applications according to CRN)	50 bar 5 MPa
Tests / approvals	
Pressure equipment directive	A possible classification to PED depends on the application and has to be carried out by the user / operator.
Safety instructions	The compatibility between medium and product material has to be checked in all applications.
Mechanical data	
Weight [g]	278.8
Materials (wetted parts)	stainless steel (1.4404 / 316L)
Sensor connection	G 1
Process connection	threaded connection 2" NPT
Remarks	
Pack quantity	1 pcs.