

# E40616

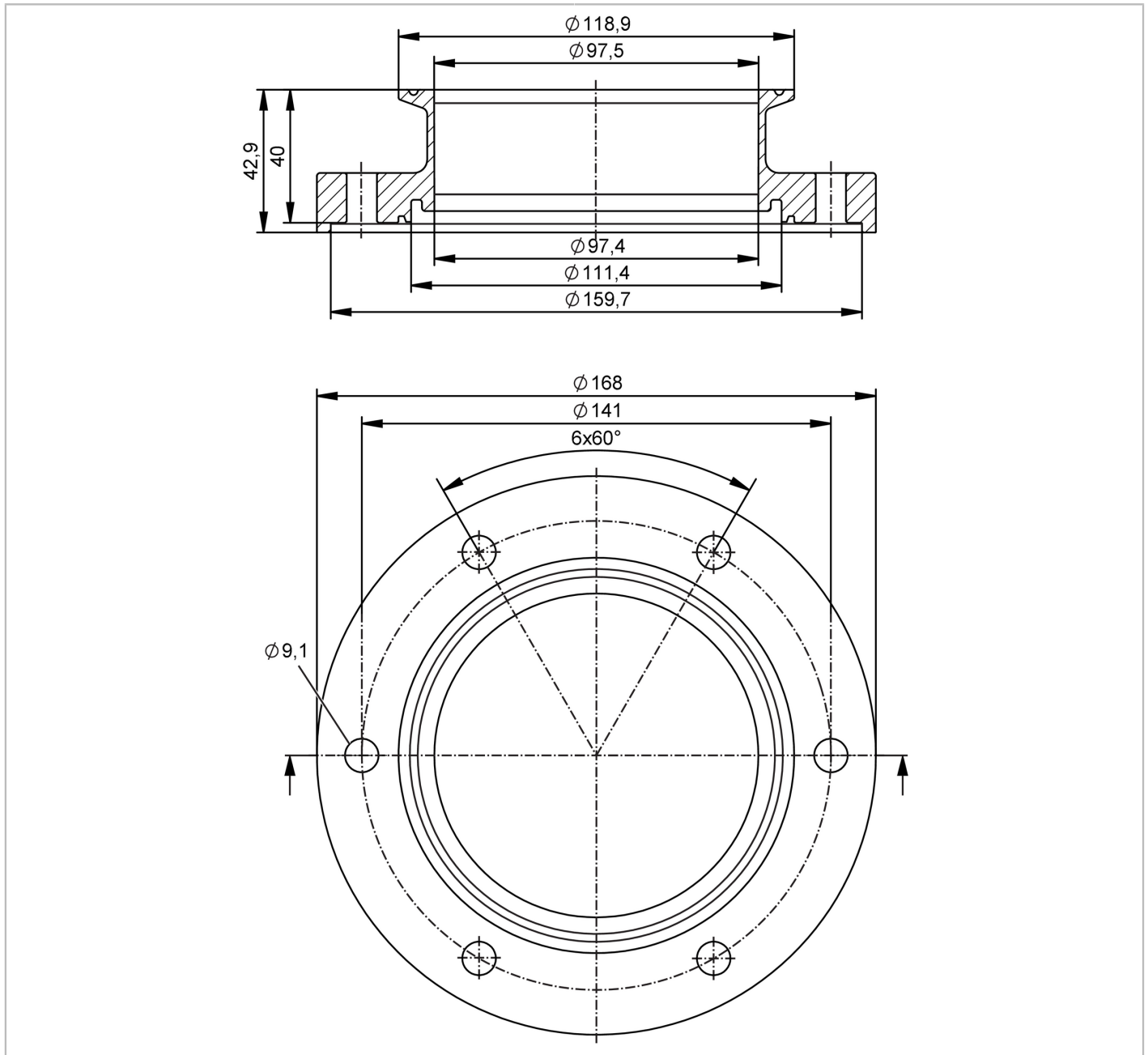

## Process adapters clamp DIN 32676 series C (ASME BPE)

ADAPT DIN32676-C DN100



Application	
Design	for flow meter SMF
Application	food and beverage industry; hygienic systems
Pressure rating	10 bar 1 MPa
Tests / approvals	
Pressure equipment directive	A possible classification to PED depends on the application and has to be carried out by the user / operator.
Safety instructions	The compatibility between medium and product material has to be checked in all applications.

# E40616



## Process adapters clamp DIN 32676 series C (ASME BPE)

ADAPT DIN32676-C DN100

Mechanical data	
Weight [g]	4937.8
Housing	tubular
Dimensions [mm]	Ø 168 / L = 42.9
Material	stainless steel (1.4404 / 316L)
Nominal diameter	DN100 (4")
Sensor connection	ifm-specific device flange
Process connection	Clamp DIN 32676 series C (ASME BPE)
Process connection suitable for pipe standard	(DIN EN 10357 series C); (DIN EN 10357 series D); (DIN 11866 series C); (BS 4825 Part 1); (ISO 2037)
Surface characteristics Ra/Rz of the wetted parts	Ra < 0.4 µm
Accessories	
Items supplied	screws 12
Remarks	
Pack quantity	2 pcs.