

# E35060

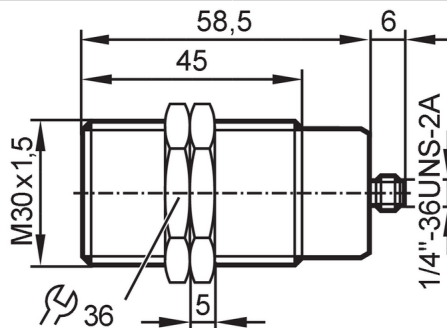

## Measuring head for infrared temperature sensors

SENSOR HEAD



1 3/4" Clamp ISO 2852

### Application

Design for infrared temperature sensors

### Operating conditions

Ambient temperature [°C] -20...250

### Mechanical data

Weight [g]	169.5
Dimensions [mm]	M30 x 1.5 / L = 64.5
Thread designation	M30 x 1.5
Material	AlMg3 black anodized; stainless steel (1.4305 / 303); lock nuts: stainless steel (1.4301 / 304); O-ring: FKM
Lens material	front lens: tempered optical glass
Tightening torque [Nm]	0.165

### Remarks

Pack quantity 1 pcs.

### Diagrams and graphs

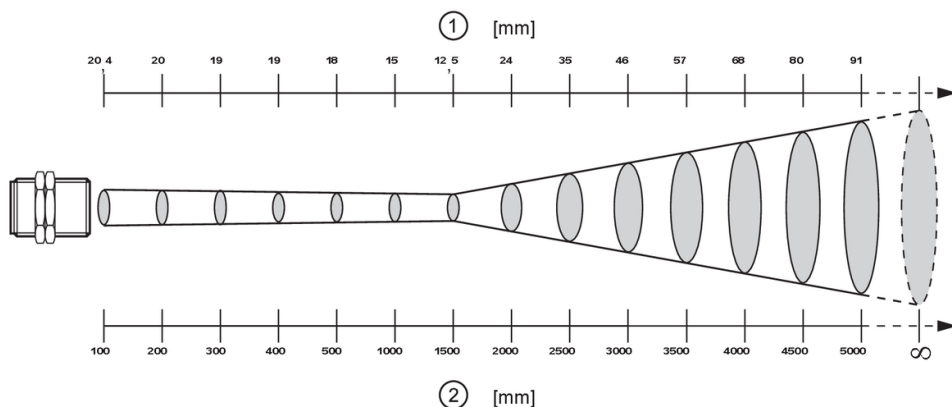

1 diameter of the measured spot

2 measuring distance