

E33350

Universal process adapter

ADAPT UNI

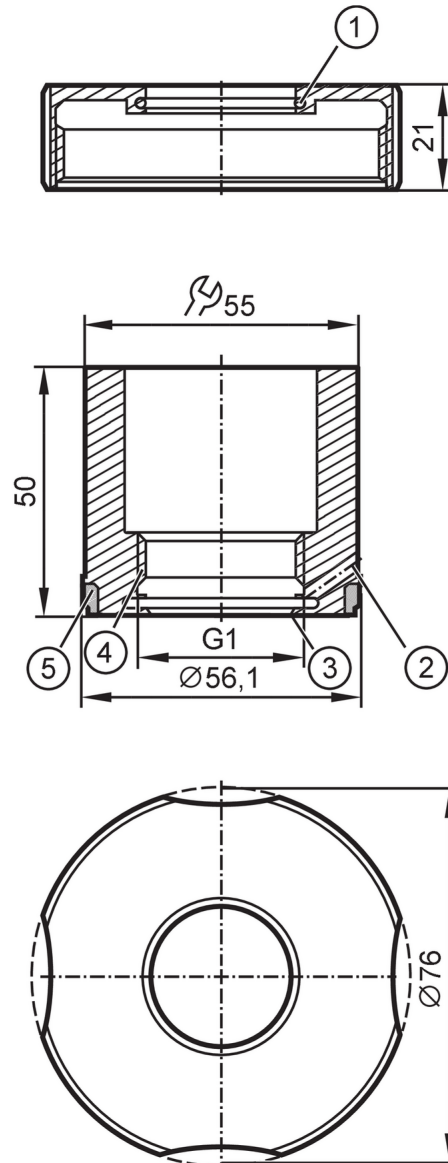

- 1 O-ring 30x2 FKM
- 2 Leakage port
- 3 sealing area
- 4 Internal thread G1 Aseptoflex Vario
- 5 Gasket silicone



Application	
Design	accessories for, PY200x, : (Anderson Weld-In Tank Shell: 71060A0003), PM17xx, : (Anderson Weld-In Tank Shell:71060A0004)
Pressure rating	16 bar 4 MPa
Tests / approvals	
Pressure equipment directive	A possible classification to PED depends on the application and has to be carried out by the user / operator.
Safety instructions	The compatibility between medium and product material has to be checked in all applications.

E33350



Universal process adapter

ADAPT UNI

Mechanical data	
Weight [g]	1019.3
Materials (wetted parts)	stainless steel (1.4435 / 316L) surface characteristics: Ra < 0,4 µm / Rz = 4 µm
Sensor connection	G 1 Aseptoflex Vario
Process connection	universal process adapter Anderson Weld-In Tank Shell: 71060A0003; 71060A0004
Sealing	Gasket
Hygienic equipment class to DIN 11866	H4
Accessories	
Items supplied	O-rings: 1 x (24 x 2 mm), EPDM, FDA compliant, E30054
	O-rings: 1 x (30 x 2 mm), FKM
	sealing rings: 1, silicone 3A and FDA compliant
Accessories (optional)	O-ring: 24 x 2, FKM, FDA compliant, E30123
	sealing ring, PEEK, FDA compliant, E30124
Remarks	
Pack quantity	1 pcs.