

E33705

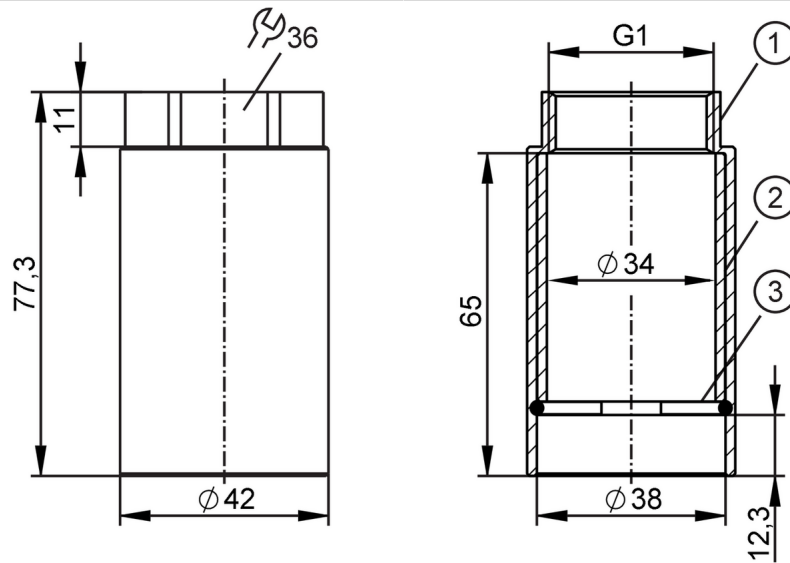

LW2120 antenna extension

ANTENNA EXTENSION /LW2120



- 1 Housing
- 2 plastic insert
- 3 retaining ring

Application

Design LW2120 antenna extension for LPR applications

Mechanical data

Weight	[g]	211.1
Dimensions	[mm]	Ø 42 / L = 77.3
Material		housing: stainless steel (1.4404 / 316L); retaining ring: stainless steel (1.4310 / 301); plastic insert: POM-C ELS
Sensor connection		G 1

Remarks

Pack quantity 1 pcs.