

E30531

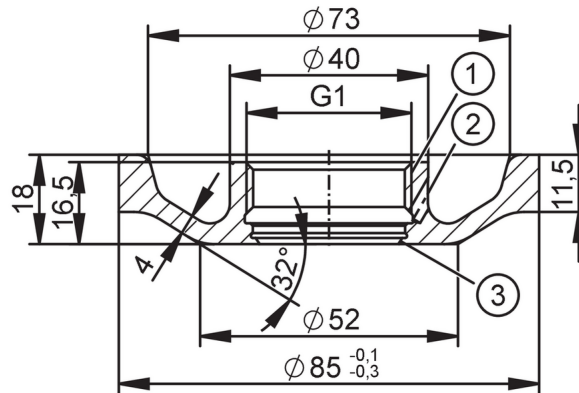

Welding adapter for process sensors

WELDING ADAPT D85 G1 V4A 3A



- 1 G1 Internal thread Aseptoflex Vario
- 2 Leakage port
- 3 sealing area



EC 1935/2004 EHEDG Certified FCM FDA

Application	
Design	with leakage port (3A)
Installation	recommended for wall thickness ≤ 6 mm and for unfavourable welding conditions
Pressure rating	16 bar 5 MPa
Note on pressure rating	for the connection sensor - adapter
Tests / approvals	
Pressure equipment directive	A possible classification to PED depends on the application and has to be carried out by the user / operator.
Safety instructions	The compatibility between medium and product material has to be checked in all applications.
Mechanical data	
Weight [g]	362
Materials (wetted parts)	Welding adapter: stainless steel (1.4435 / 316L) surface characteristics: $R_a < 0,4 \mu\text{m}$ / $R_z = 4 \mu\text{m}$
Sensor connection	G 1 Internal thread Aseptoflex Vario
Process connection	Welding adapter $\varnothing 85$ mm
Sealing	Gasket
Accessories	
Items supplied	O-rings: 1 x (24 x 2 mm), EPDM, E30054
Accessories (optional)	O-ring: 1 x 24 x 2, FKM, FDA compliant, E30123
	Welding mandrel, E30452
	welding mandrel, water-cooled, E30532
	leak test, E30530
	grinding protection, E30162
Remarks	
Pack quantity	1 pcs.