

E30471

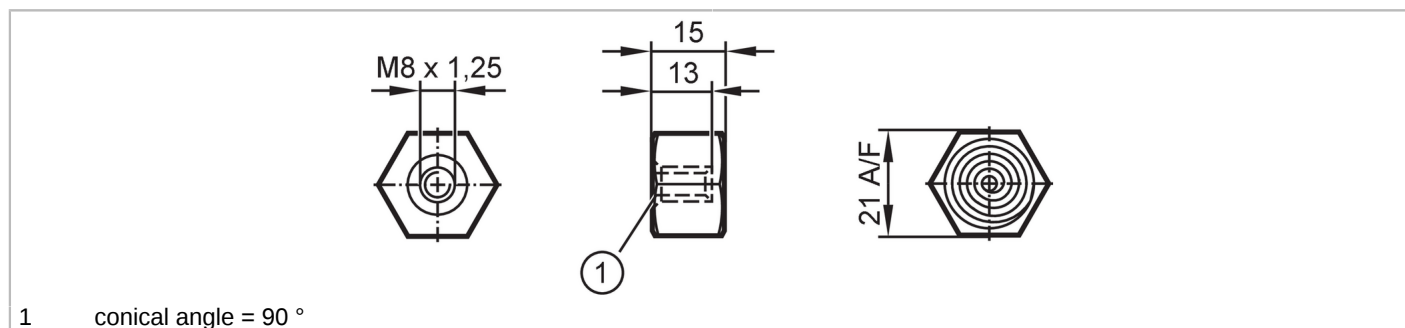

Adhesive adapter for acceleration and vibration sensors

MOUNTING STUD M8 90° CONE HEX 21 MM



Application	
Design	for efector octavis
Mechanical data	
Weight [g]	39.6
Material	stainless steel (1.4305 / 303)
Sensor connection	M8 x 1,25 Internal thread with 90° cone
Remarks	
Pack quantity	1 pcs.