

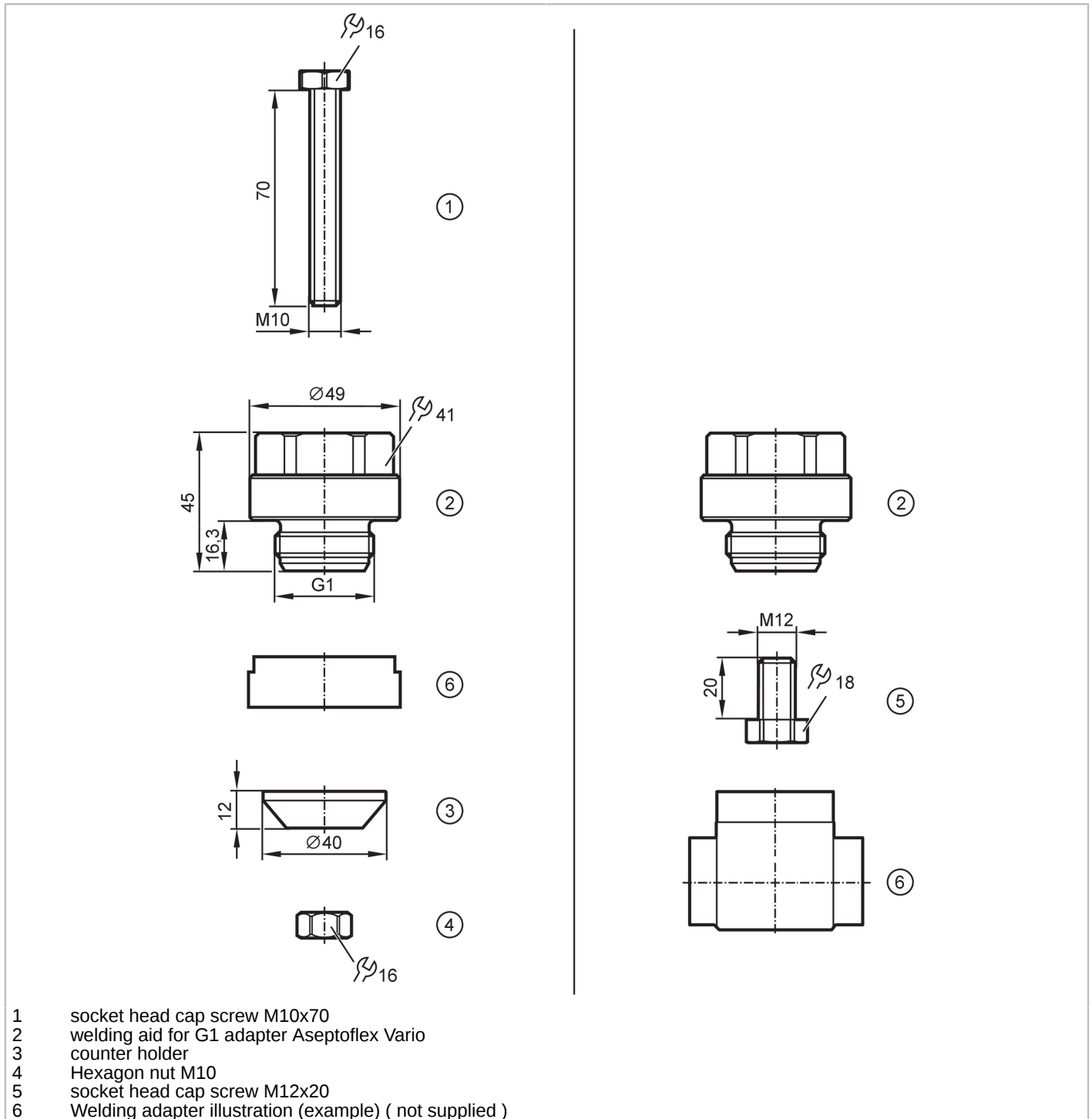

Welding mandrel for process connections

WELD MANDREL ADAPT G1



Application	
Design	welding aid with sealing edge protection for Aseptoflex Vario
Application	heat dissipation during the welding process
Mechanical data	
Weight	[g] 679
Material	brass (2.0321 / CW508L); stainless steel
Process connection	G 1 Aseptoflex Vario

E30452



Welding mandrel for process connections

WELD MANDREL ADAPT G1

Remarks	
Pack quantity	1 pcs.