

E21087

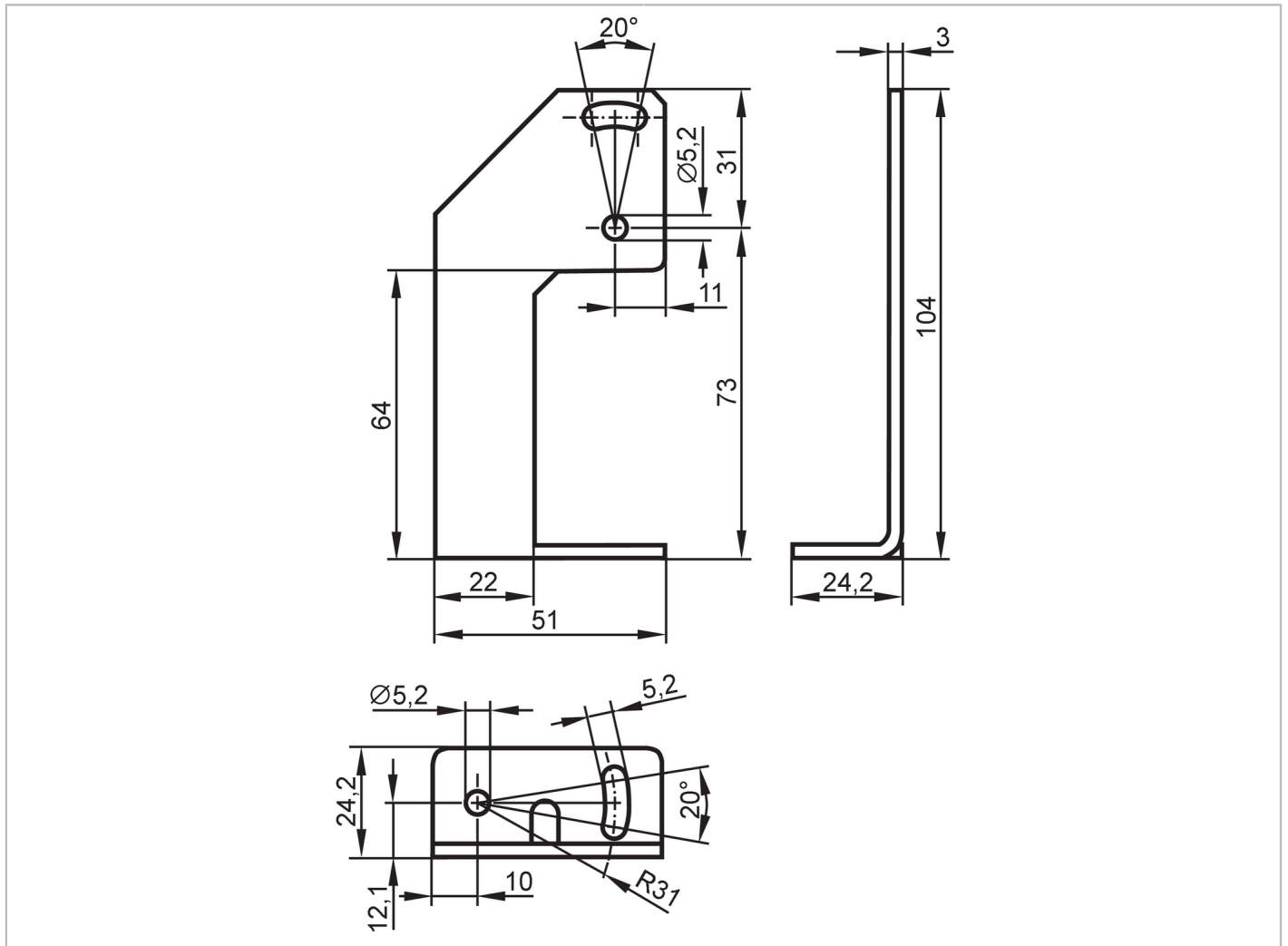

Angle bracket

O5 STANDARD BRACKET



Application	
Design	for types O5
Mechanical data	
Weight [g]	122
Dimensions [mm]	104 x 51 x 24.2
Material	stainless steel (1.4571/316Ti)
Accessories	
Items supplied	cylinder screws: 2 x (M5 x 28 mm) Nuts: 2 x M5 washers: 2
Remarks	
Pack quantity	1 pcs.