

E11627

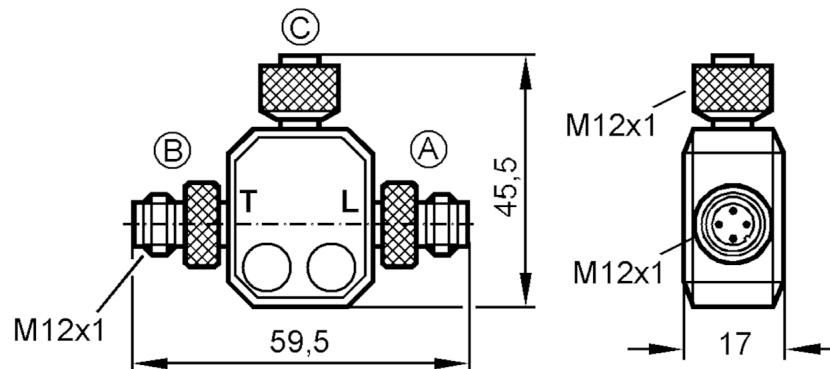

T-splitter

T SPLITTER M12/2XUS



Electrical data

Operating voltage	[V]	< 30 AC / < 36 DC
Max. current load per module/slot	[A]	3
Max. current load total	[A]	3

Operating conditions

Ambient temperature	[°C]	-25...90
Protection		IP 68

Mechanical data

Weight	[g]	39.7
Material		housing: PUR
Material nut		brass, nickel-plated

Accessories

Items supplied		Protective caps: 1
----------------	--	--------------------

Remarks

Pack quantity		1 pcs.
---------------	--	--------

E11627



T-splitter

T SPLITTER M12/2XUS

Electrical connection

Connection

AN_i_0925_GG

Original Scale Drawing (MTD)

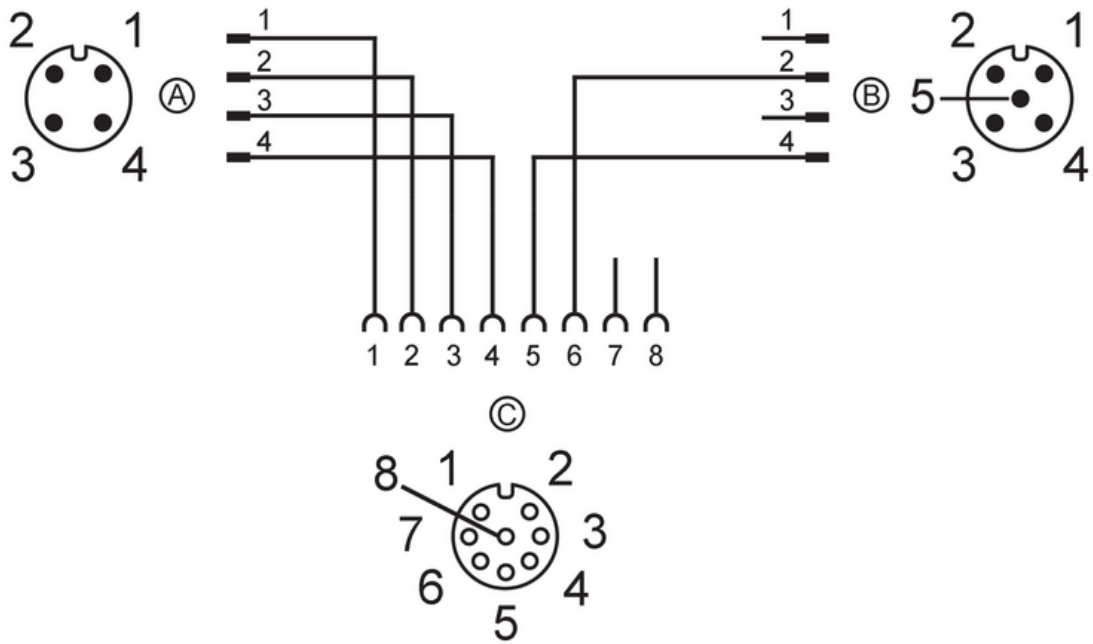

↓ 32% ↑ 312,5%

EPS Source
Product Scale Drawing
Frame Size: 75 mm x 45 mm

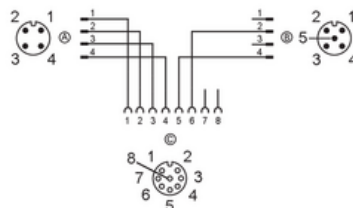

Connector: 1 x M12; Locking: brass, nickel-plated