

# E11566

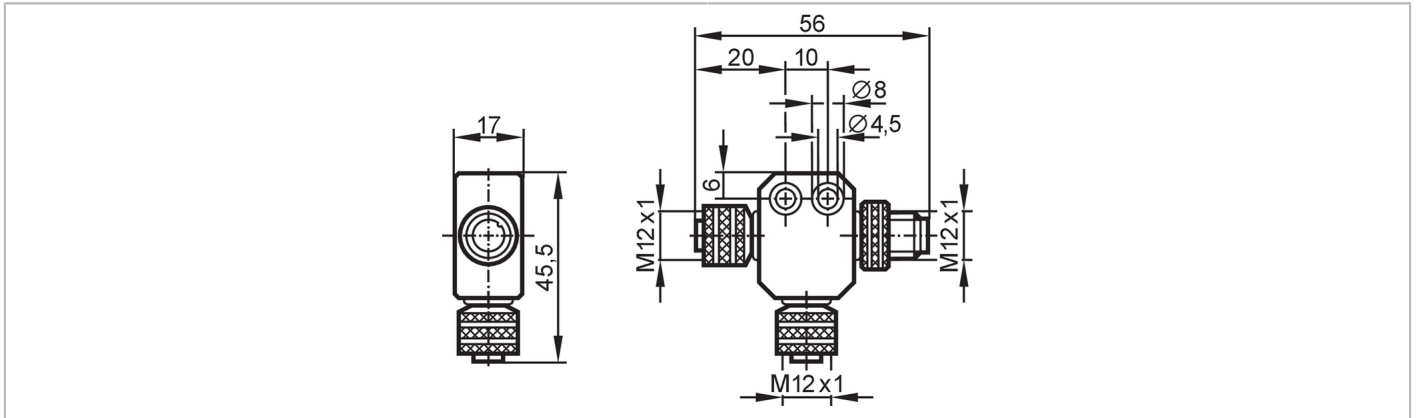

## T-splitter

T SPLITTER M12/2XUS



Application	
Design	for pressure sensors PNI
Electrical data	
Operating voltage [V]	< 30 AC / < 36 DC
Max. current load per module/slot [A]	3
Max. current load total [A]	3
Operating conditions	
Ambient temperature [°C]	-25...90
Protection	IP 68
Mechanical data	
Weight [g]	38.2
Material	housing: PUR
Remarks	
Remarks	orientation connectors A/B horizontal (for a vertical sensor)
Pack quantity	1 pcs.



## T-splitter

T SPLITTER M12/2XUS

### Electrical connection

#### Connection

AN\_i\_0711\_GG

Original Scale Drawing (MTD)

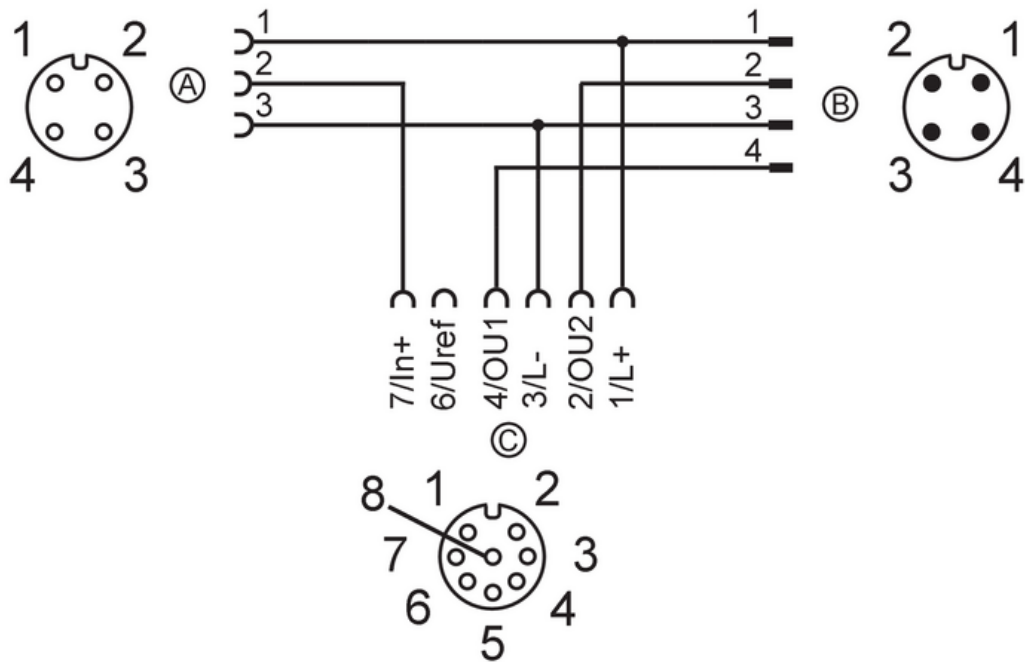

↘ 32% ↗ 312,5%

EPS Source  
Product Scale Drawing  
Frame Size: 75 mm x 45 mm

