

# E10077

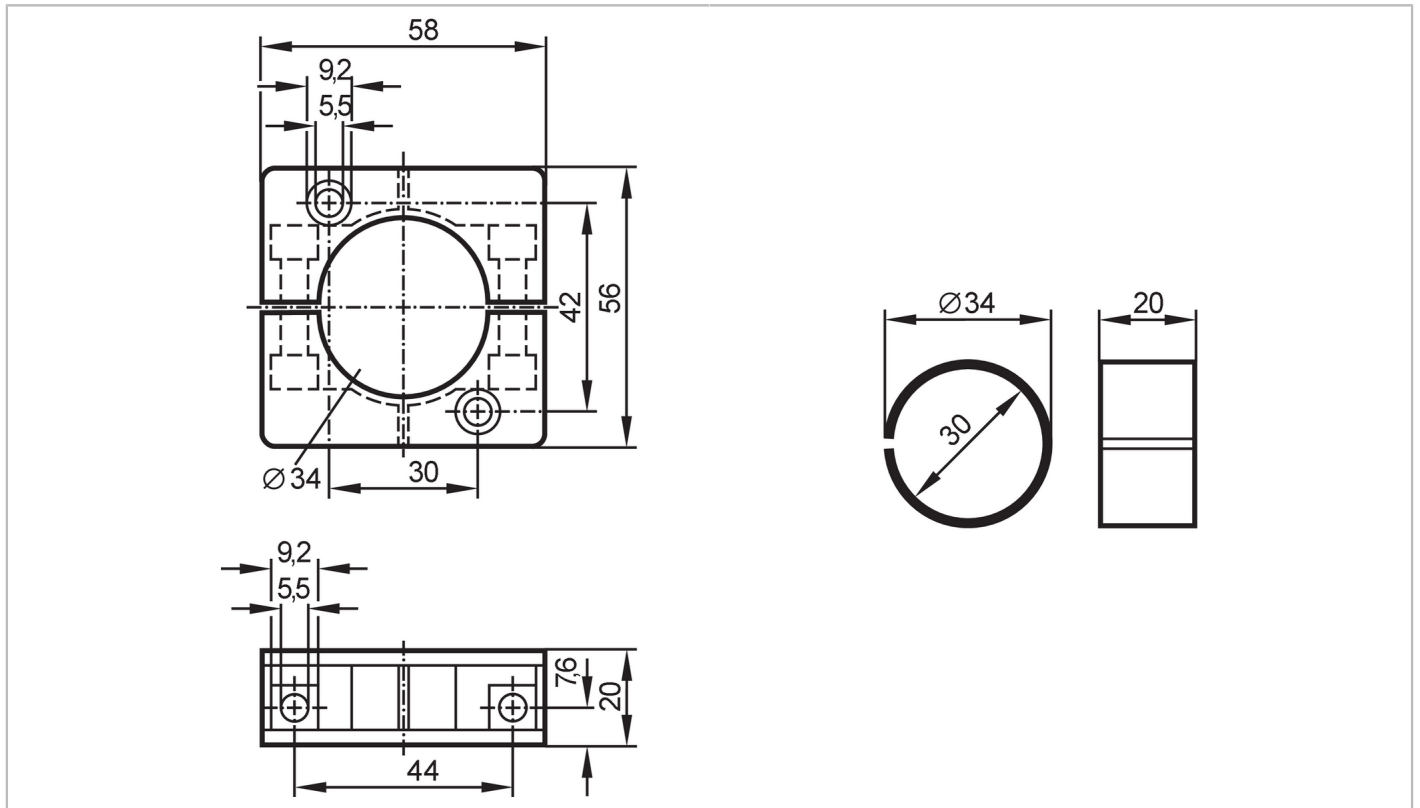

## Mounting clamp

MOUNTING CLAMP II



Application	
Design	with reducing bush
Mechanical data	
Weight [g]	56.8
Dimensions [mm]	56 x 58 x 20
Inside diameter [mm]	34
Material	Mounting clamp: PBT
Accessories	
Items supplied	socket head screws: 2 x (M5 x 50 mm) spring washers: 2
Remarks	
Pack quantity	1 pcs.