

E10017

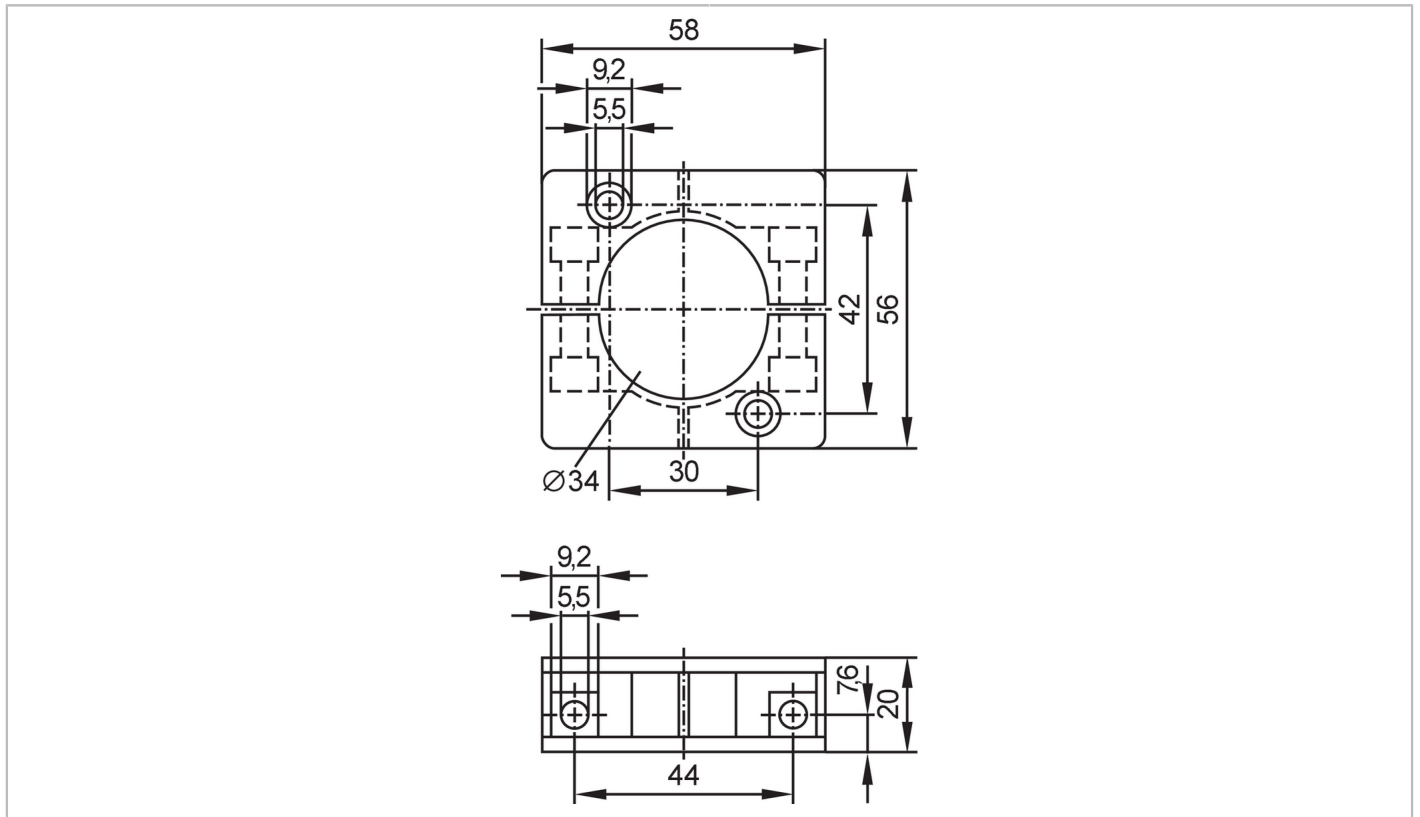

Mounting clamp

MOUNTING CLAMP D34 MM



Mechanical data

Weight	[g]	51.9
Dimensions	[mm]	56 x 58 x 20
Inside diameter	[mm]	34
Material		Mounting clamp: PBT

Accessories

Items supplied	socket head screws: 2 x (M5 x 50 mm)
	spring washers: 2

Remarks

Pack quantity	1 pcs.
---------------	--------