

CR2530

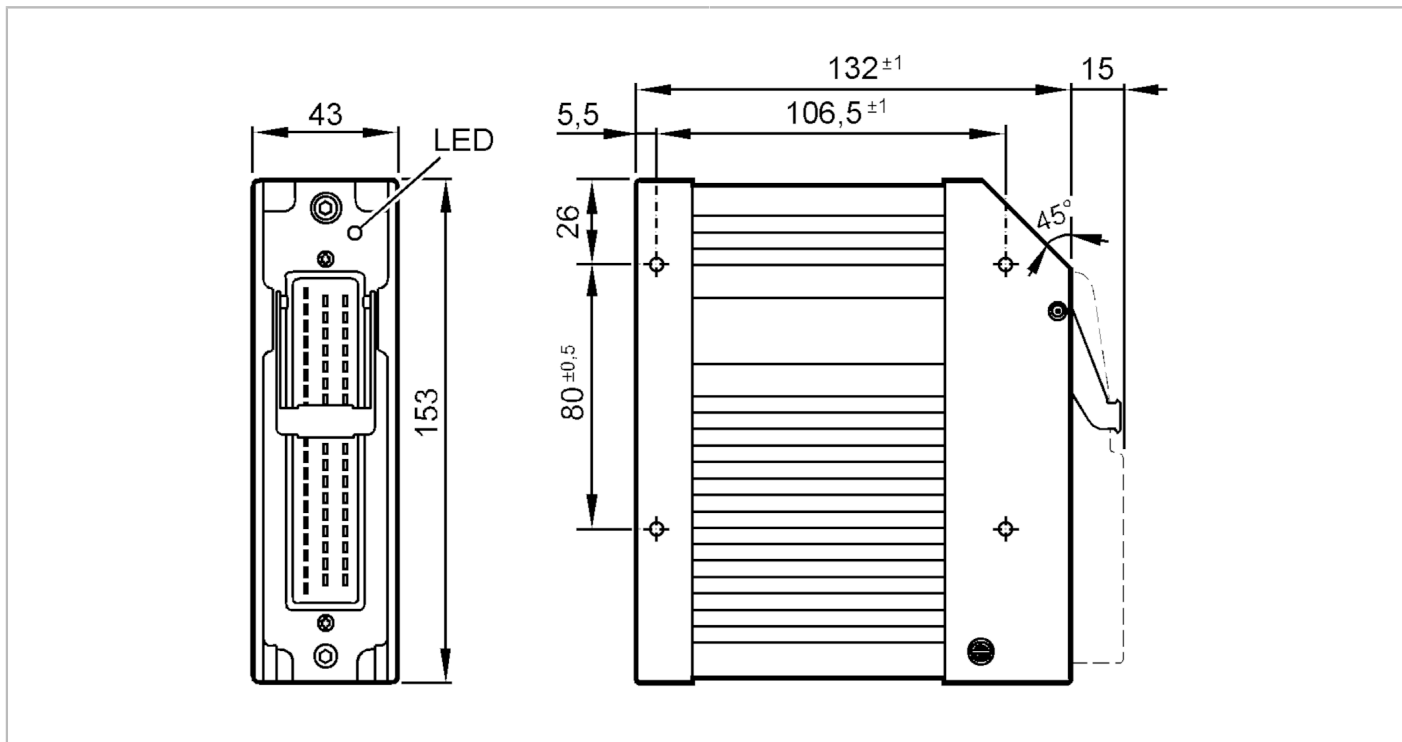

Programmable controller for mobile machines

R360/SmartController 32E/A



Electrical data	
Operating voltage	[V] 8...32 DC
Inputs / outputs	
Total number of inputs and outputs	32
Number of inputs and outputs	Number of digital inputs: 16; Number of analog inputs: 4; Number of frequency inputs: 4; Number of resistor inputs: 2; Number of digital outputs: 16; Number of analog outputs: 2
Inputs	
Number of frequency inputs	4
Number of resistor inputs	2
Number of digital inputs	16
Number of analog inputs	4
Analog input (current)	[mA] 0...20
Analog input (voltage)	[V] 0...32
Outputs	
Number of digital outputs	16
Number of analog outputs	2
Analog voltage output	[V] 0.2...10
Number of PWM outputs	12
Number of PWM-I outputs	2
Software / programming	
Parameter setting options	input/output functions
PLC function to IEC 61131-3	yes

CR2530



Programmable controller for mobile machines

R360/SmartController 32E/A

Interfaces	
Number of CAN interfaces	2
Tests / approvals	
MTTF [years]	91
Mechanical data	
Weight [g]	1078.8
Housing	rectangular
Type of mounting	screw mounting
Dimensions [mm]	153 x 147 x 43
Remarks	
Pack quantity	1 pcs.