

II5493

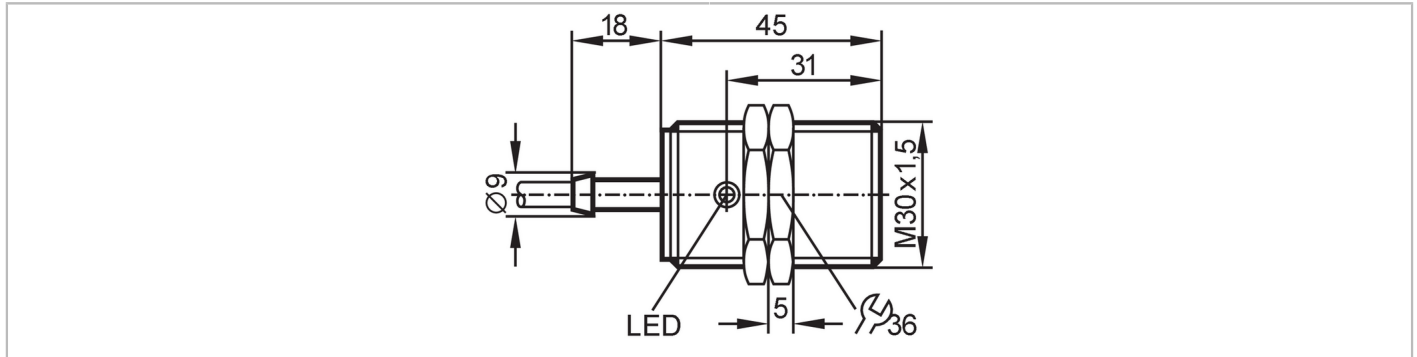

Inductive sensor

IIB2010-FRKG/PH



Product characteristics

Electrical design	PNP/NPN
Output function	normally open / normally closed; (selectable)
Sensing range [mm]	10
Housing	threaded type
Dimensions [mm]	M30 x 1.5 / L = 45

Electrical data

Operating voltage [V]	10...55 DC
Protection class	III
Reverse polarity protection	yes

Outputs

Electrical design	PNP/NPN
Output function	normally open / normally closed; (selectable)
Max. voltage drop switching output DC [V]	4.6
Minimum load current [mA]	4
Max. leakage current [mA]	0.5
Permanent current rating of switching output DC [mA]	400
Switching frequency DC [Hz]	450
Short-circuit protection	yes
Type of short-circuit protection	pulsed
Overload protection	yes

Detection zone

Sensing range [mm]	10
Real sensing range Sr [mm]	10 ± 10 %
Operating distance [mm]	0...8.1

Accuracy / deviations

Correction factor	steel: 1 / stainless steel: 0.7 / brass: 0.4 / aluminium: 0.3 / copper: 0.2
Hysteresis [% of Sr]	1...15
Switch point drift [% of Sr]	-10...10

II5493



Inductive sensor

IIB2010-FRKG/PH

Operating conditions		
Ambient temperature	[°C]	-25...80
Protection		IP 67
Tests / approvals		
EMC	EN 60947-5-2	
	EN 55011	class B
MTTF	[years]	1568
Mechanical data		
Weight	[g]	205
Housing		threaded type
Mounting		flush mountable
Dimensions	[mm]	M30 x 1.5 / L = 45
Thread designation		M30 x 1.5
Materials		housing: brass nickel-plated; sensing face: PBT
Displays / operating elements		
Display	switching status	1 x LED, yellow
Accessories		
Items supplied		lock nuts: 2
Remarks		
Pack quantity		1 pcs.
Electrical connection		
Cable: 2 m, PUR / PVC; 2 x 0.5 mm ²		
Connection		

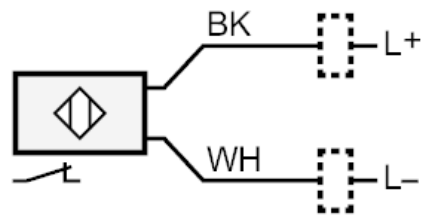
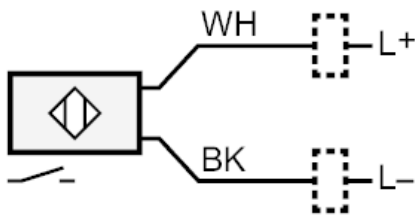

Core colours :
BK = black
WH = white