

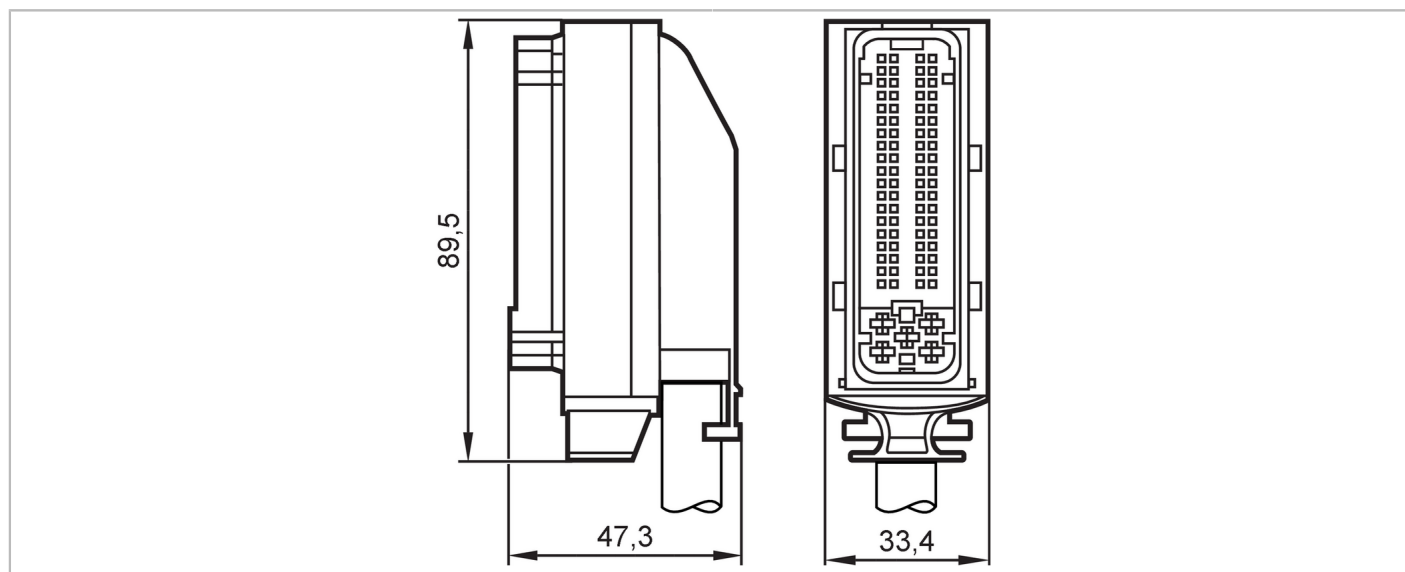

Zelfbedraadbare AMP-aansluitstekker

ecomatConnection Set Code-B



Omgevingsvariabelen

Beschermklasse	IP 67; (alleen in combinatie met afdichting van de afzonderlijke aders (niet meegeleverd))
----------------	--

Mechanische eigenschappen

Gewicht	[g]	75,3
Afmetingen	[mm]	89,5 x 33,4 x 47,3

Opmerkingen

Verpakkingseenheid	1 stuk
--------------------	--------