

E10750

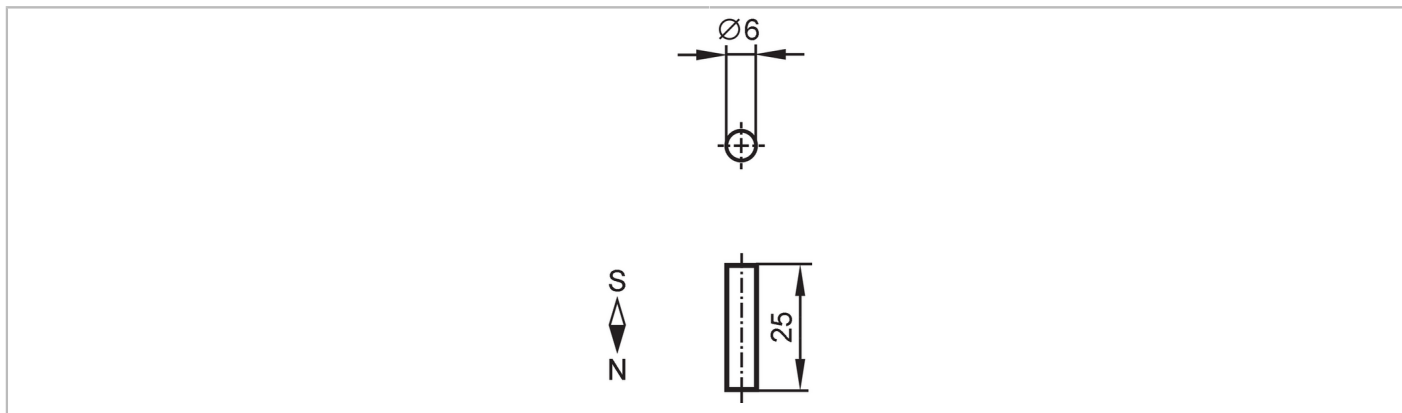

Dempingsmagneet

MAGNET M2.0/ALNICO



Omgevingsvariabelen

Omgevingstemperatuur	[°C]	-100...500
----------------------	------	------------

Mechanische eigenschappen

Gewicht	[g]	6,9
---------	-----	-----

Afmetingen	[mm]	Ø 6 / L = 25
------------	------	--------------

Materialen		magneet: AlNiCo
------------	--	-----------------

Magneetveldsterkte	[mT]	110
--------------------	------	-----

Opmerkingen

Verpakkingseenheid		1 stuk
--------------------	--	--------