

# LDH110

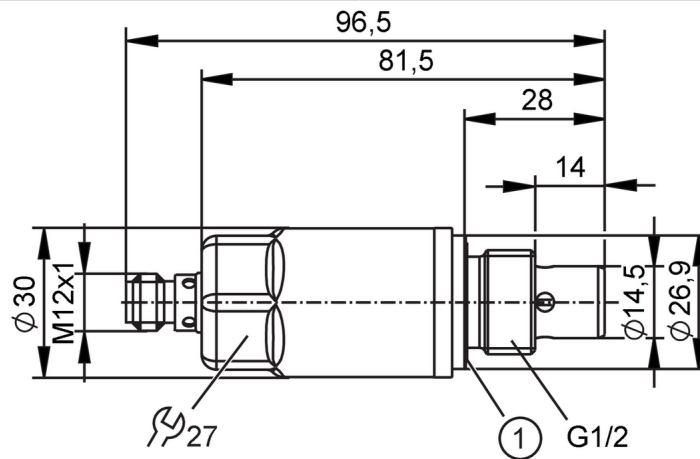

## Oil humidity sensor

OIL HUMIDITY SENSOR ANALOG



1 Sealing



### Product characteristics

Number of inputs and outputs	Number of analogue outputs: 2
Process connection	threaded connection G 1/2

### Application

Special feature	Gold-plated contacts
Media	mineral oils; synthetic esters; biodegradable oils
Cannot be used for	See operating instructions, chapter "Intended use".
Medium temperature [°C]	-40...120
Pressure rating	50 bar   5 MPa
Vacuum resistance [mbar]	-1000

### Electrical data

Operating voltage [V]	9...33 DC
Current consumption [mA]	< 50
Protection class	III
Reverse polarity protection	yes
Power-on delay time [s]	2
Max. current load total [A]	0.085

### Inputs / outputs

Number of inputs and outputs	Number of analogue outputs: 2
------------------------------	-------------------------------

### Outputs

Total number of outputs	2
Output signal	analogue signal
Output function	analogue output humidity / temperature
Number of analogue outputs	2
Analogue current output [mA]	4...20
Max. load [ $\Omega$ ]	(UB - 5V) * 50

### Measuring/setting range

Measuring range [% RH]	0...100
------------------------	---------

# LDH110



## Oil humidity sensor

OIL HUMIDITY SENSOR ANALOG

<b>Temperature measurement</b>		
Measuring range	[°C]	-40...120
<b>Accuracy / deviations</b>		
Accuracy		± 3%; ( ± 5 % in the range < 10 %, > 90 %)
Repeatability		± 0,5 %
Resolution	[%]	12 Bit
<b>Temperature measurement</b>		
Accuracy	[K]	± 1
Repeatability	[K]	± 0,5
Resolution	[%]	12 Bit process value
<b>Response times</b>		
Response time	[s]	oil: T09 < 30
<b>Temperature measurement</b>		
Response time	[s]	oil: T09 < 30
<b>Operating conditions</b>		
Ambient temperature	[°C]	-40...85
Storage temperature	[°C]	-40...85
Max. relative air humidity	[%]	100
Protection		IP 68; IP 69K; (7 days / 3 m water depth / 0.3 bar: IP 68)
<b>Tests / approvals</b>		
EMC	DIN EN 61000-6-2	
	DIN EN 61000-6-4	
Shock resistance	DIN EN 60068-2-27	50 g (11 ms)
Vibration resistance	DIN EN 60068-2-6	20 g (10...2000 Hz)
MTTF	[years]	284
UL approval	File number UL	E364788
Pressure Equipment Directive		Sound engineering practice; can be used for group 2 fluids; group 1 fluids on request
<b>Mechanical data</b>		
Weight	[g]	118.5
Materials		stainless steel (316L/1.4404); PEI; Sealing: FKM
Materials (wetted parts)		stainless steel (316L/1.4404); PA6 GF50; epoxy resin; Sealing: NBR
Process connection		threaded connection G 1/2
<b>Remarks</b>		
Remarks		accuracy values expressed in percent refer to the measuring span
Pack quantity		1 pcs.
<b>Electrical connection</b>		
Connector: 1 x M12 (EN 61067-2-101); coding: A; Contacts: 4, gold-plated		

# LDH110



## Oil humidity sensor

OIL HUMIDITY SENSOR ANALOG

### Connection

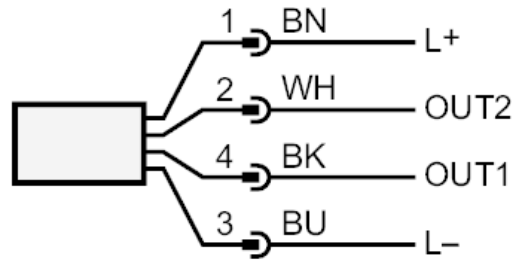

OUT1	analogue output temperature
OUT2	analogue output humidity
	colours to DIN EN 60947-5-2
BK=	black
BN=	brown
BU=	blue
WH=	white