

# RN6024



## Absolute singleturn encoder with solid shaft

RN-4096-G24/L1B

Article no longer available - archive entry

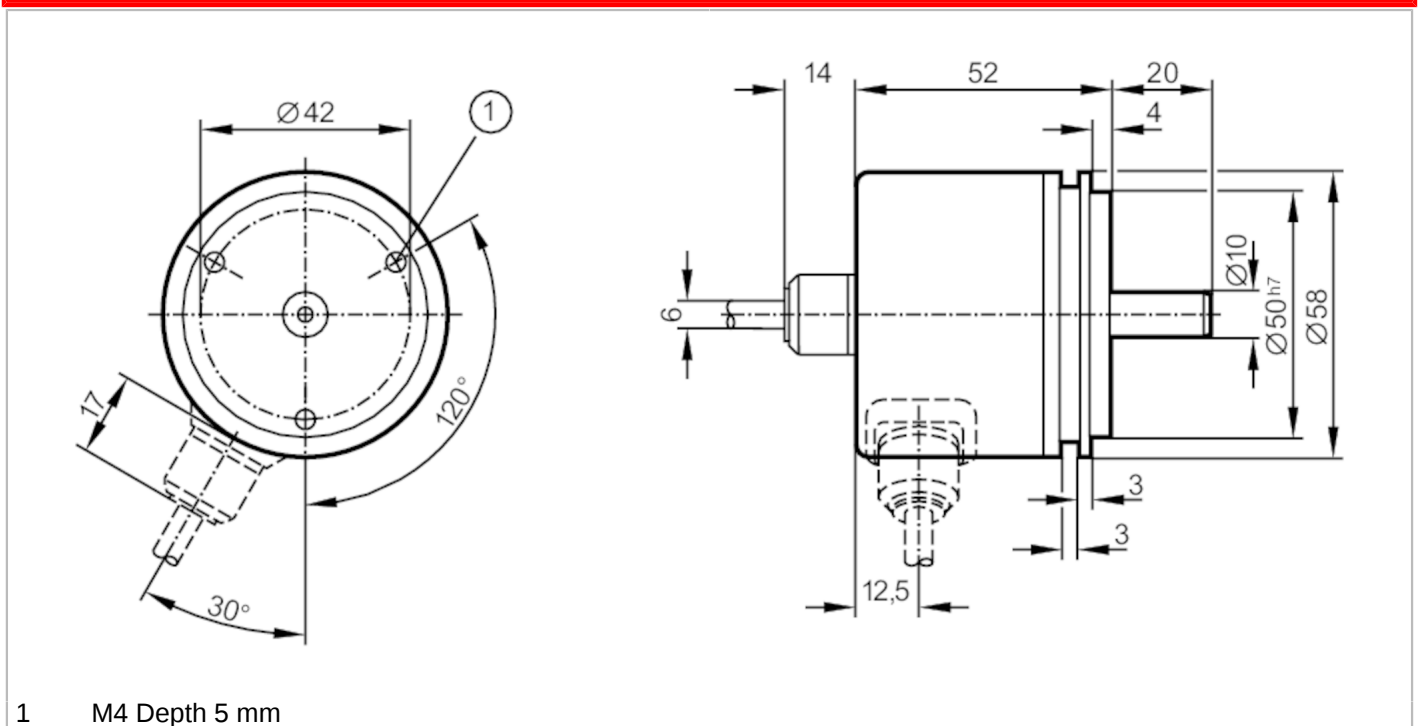

1 M4 Depth 5 mm



### Product characteristics

Resolution	4096 steps; 12 bit
Shaft design	solid shaft
Shaft diameter [mm]	10

### Electrical data

Operating voltage [V]	10...30 DC
Current consumption [mA]	< 250
Max. revolution electrical [U/min]	1500

### Outputs

Electrical design	HTL
Max. current load per output [mA]	20
Code	Gray code; (increasing code values when turned clockwise (seen on the shaft))

### Measuring/setting range

Resolution	4096 steps; 12 bit
------------	--------------------

### Operating conditions

Ambient temperature [°C]	-20...70
Storage temperature [°C]	-30...100
Max. relative air humidity [%]	98
Protection	IP 64

### Tests / approvals

Shock resistance	100 g (6 ms)
Vibration resistance	10 g (55...2000 Hz)

# RN6024



## Absolute singleturn encoder with solid shaft

RN-4096-G24/L1B

Mechanical data		
Dimensions	[mm]	Ø 58 / L = 52
Materials		aluminium
Max. revolution, mechanical	[U/min]	10000
Max. starting torque	[Nm]	1
Reference temperature torque	[°C]	20
Shaft design		solid shaft
Shaft diameter	[mm]	10
Shaft material		steel (1.4104)
Max. shaft load axial (at the shaft end)	[N]	10
Max. shaft load radial (at the shaft end)	[N]	20

### Electrical connection

Cable: 1 m, PUR; Maximum cable length: 100 m; axial

brown	10...30V
yellow/brown	10...30V sensor
white	0V
white/yellow	0V sensor
brown/green	bit 12 (MSB)
white/green	bit 11
red/blue	bit 10
grey/pink	bit 9
lilac	bit 8
black	bit 7
red	bit 6
blue	bit 5
pink	bit 4
grey	bit 3
grey/brown	bit 2
white/pink	bit 1
screen	housing

Article no longer available - archive entry