

VSA004

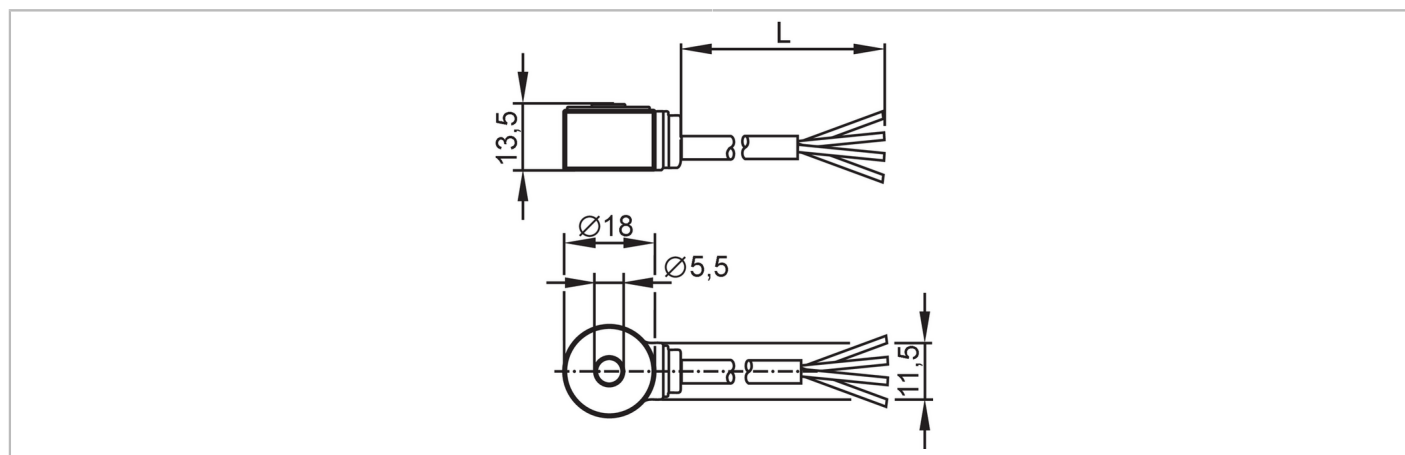

Acceleration sensor

VIBRATION SENSOR



Product characteristics		
Measuring range of vibration	[g]	-25...25
Frequency range	[Hz]	1...10000
Measuring principle		capacitive
Application		
Special feature		Halogen-free; Screened cable; Drag chain suitability
Design		for connection to external diagnostic electronics VSE
Application		vibration detection
Electrical data		
Operating voltage	[V]	7.2...10.8 DC
Current consumption	[mA]	< 15
Min. insulation resistance	[MΩ]	100; (500 V DC)
Protection class		III
Reverse polarity protection		yes
Sensor type		microelectromechanical system (MEMS)
Outputs		
Analogue current output	[mA]	0...10
Max. load	[Ω]	300
Measuring/setting range		
Measuring range of vibration	[g]	-25...25
Frequency range	[Hz]	1...10000
Measuring principle		capacitive
Sensitivity	[μA/g]	142
Number of measurement axes		1
Accuracy / deviations		
Linearity deviation		0,2 %
Operating conditions		
Ambient temperature	[°C]	-20...80
Note on ambient temperature		cULus: < 80 °C

VSA004



Acceleration sensor

VIBRATION SENSOR

Storage temperature	[°C]	-20...80
Max. relative air humidity	[%]	80; (40 °C: 50 % non condensing)
Protection		IP 67

Tests / approvals

EMC	EN 61000-6-2	
	EN 61000-6-3	
Shock resistance	DIN EN 60068-2-27	50 g 11 ms
Vibration resistance	DIN EN 60068-2-6	20 g / 10 ... 2000 Hz
MTTF	[years]	2660

Mechanical data

Weight	[g]	120.5
Type of mounting		mounting screw
Materials		housing: stainless steel (316L/1.4404)
Tightening torque	[Nm]	5
Mechanische Überlastfestigkeit	[g]	500
Drag chain suitability		yes
Drag chain suitability	bending radius for fixed installation	: min. 4 x cable diameter
	bending radius for flexible use	: min. 15 x cable diameter

Accessories

Items supplied	head cap screw: 1 x (M5 x 20 mm), Torx 15
----------------	-------------------------------------------

Remarks

Pack quantity	1 pcs.
---------------	--------

Electrical connection

Cable: 3 m, PUR, Halogen-free, Ø 4 mm, shielded; Maximum cable length: 250 m; drain wire connected to the housing; 4 x 0.14 mm²

blue	GND
black	test
brown	L+
white	Out
Screen	drain wire